

R•O•M - Series IV MHS Shutter Installation Instructions



Congratulations on your purchase of the R•O•M Roll-Up Shutter Door!

Please read and carefully follow these instructions!

You will need the following parts and tools for installing your Roll-up Door; please note that these are not included with your system.

- Fasteners for drip rail and track
(Recommended: Self-tapping hex-head #10 machine or sheet metal screws)
- Drill
- Drill bits-#29, 11/64" 3/16", 3/8", and 1/2"
- Clear indoor/outdoor silicone sealant
- Screwdriver – Phillips
- Wire cutters
- Wire crimp
- Tape measure
- Marking pen
- Pop rivet gun for 3/16" pop rivets
- Rubber headed mallet
- Pliers/Vise Grips
- Wire nuts and/or solderless connector for joining 20-gauge wires to vehicle wiring if power locks are required
- Single Pole Double Throw Momentary Switches for Lock Input Switches (On)-Off-(On) if power locks are required

Overview

For a successful installation of the R•O•M Roll-up Shutter Door, follow these steps

- 1) Unpacking
- 2) Pre-Drilling Holes
- 3) Attaching the Sill Plate
- 4) Attaching the Pennant Plates
- 5) Hanging the Counterbalances
- 6) Hanging the Curtain
- 7) Attaching the Strike Blocks
- 8) DuroStrip™ LED Compartment Lighting
- 9) Installing the Power Lock
- 10) Attaching the Weather Stripping
- 11) Attaching the Track
- 12) Installing the Drip Rail
- 13) Installing the Pull Strap
- 14) Testing the Door Operation
- 15) Testing Interior Release Operation (optional)

R•O•M - Series IV MHS Shutter Installation Instructions



1. Unpacking

- Unpack and carefully lay out all of the parts. The shutter if unrolled should be placed on a smooth, clean, soft surface to prevent scratching the finish on the slats.
- Make sure all parts shown on the assembly drawing on page 13 are included.

2. Pre-Drilling Holes

Note: If your process involves pre-drilling all the holes in body prior to the finishing operation, follow these steps. If you do not pre-drill the holes, they must be drilled as you install the components.

Pre-drilling using templates

- If pre-drilling with templates, drill holes for track, pennant plates, and drip rail at this time.

Pre-drilling using door parts

- Looking into the compartment, place the pennant plate with right hand pennant plate label in the top right of the compartment as shown in Fig. 1. Make sure it is $\frac{1}{4}$ " from the top of the compartment and $1\text{-}\frac{5}{8}$ " from the vehicle skin.
- Match, drill the plate and track with an $\frac{11}{64}$ " drill.
- Position the track between the header and the bottom of the compartment. Make sure the bottom of the track touches the bottom of the compartment. The finishing flange should be flush against the skin of the vehicle. Optional track configurations are shown in Fig. 2.

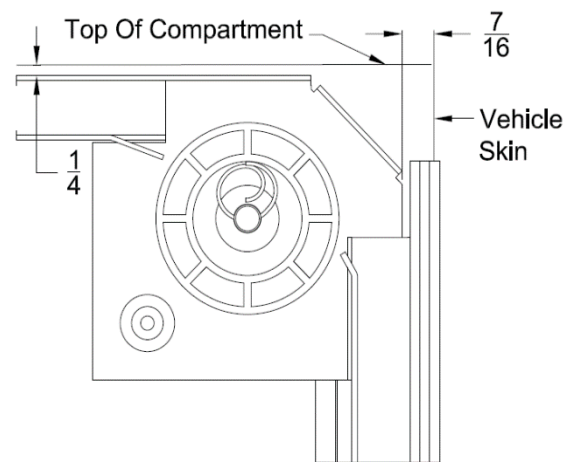

Fig. 1



Fig. 2

Note: If the sill plate option is included, place the track on the sill plate or $\frac{1}{8}$ " up from the bottom of the compartment prior to drilling.

- If pre-drilled track was ordered, match drill $\frac{11}{64}$ " holes in the vehicle body where slots are present in the track.
- If the manual locking option is included, match drill $\frac{3}{8}$ " holes in the side of the vehicle for the locking rod, using the pre-drilled hole in the track as a guide.

R•O•M - Series IV MHS Shutter Installation Instructions



- f) Center the base section of the drip rail/top seal in the compartment opening flush against the header. The ends should be even with the outer finishing flange on the track.
- g) Drill holes in the drip rail where necessary for attachment. The maximum fastener length should be $5/16"$. A hex head fastener is recommended for easy removal of the drip rail. Use the centering groove on the drip rail when installing the screws.

Do not attach drip rail until step 12!

3. Attaching the Sill Plate (optional)

- a) Place the sill plate in the center of the bottom compartment. The notches should be on the top as shown in Fig. 3.
- b) Make sure the bottom of the compartment is clean, then remove the backing from the tape on the sill plate and attach.

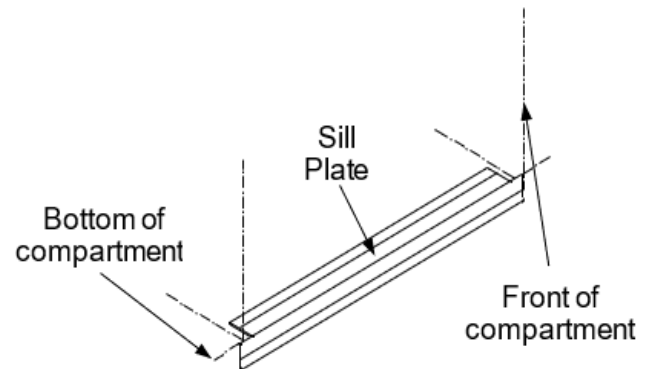

Fig. 3

4. Attaching the Pennant Plates

- a) Mount the pennant plates. Making sure the top track runs level in the compartment.

5. Hanging the Counterbalances

- a) Prior to installing counterbalances, be sure cotter pin on spool is bent to prevent it from coming out.

Place the left and right spring counterbalance assemblies on the compartment walls with the edge of the mounting bracket flush against the end of the track and $0.250"$ from the top of track to the top of the counterbalance mounting plate (Fig. 4). Drill $11/64"$ diameter holes in the compartment.

- b) Attach the counterbalance to the wall of the compartment. Be sure the cable end is facing toward the curtain when mounted to the wall. The cable needs to be pulled out before attaching to the curtain. The cables will line up with the holes in the top slat.

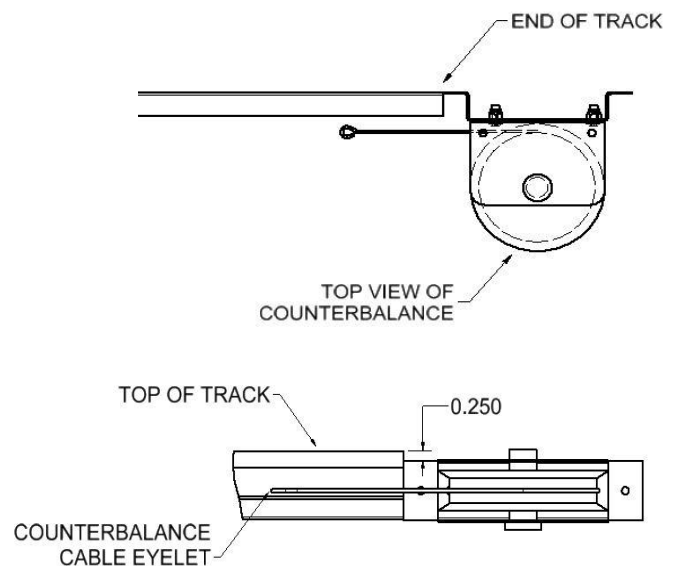

Fig. 4

R•O•M - Series IV MHS Shutter Installation Instructions



6. Hanging the Curtain

- a) Feed the top slat of the shutter over the nylon rollers and into the top track (Fig. 5). Insert the curtain until the bottom rail is against the header.

Note: *The curtain will not stay in place; it will need to be held in the open position.*

- b) Pull the counterbalance cable out and attach the cable eyelet to the top slat of the curtain using the hardware provided. Be sure the cable eyelet is attached on the curved side of the top slat (inside face of slat).

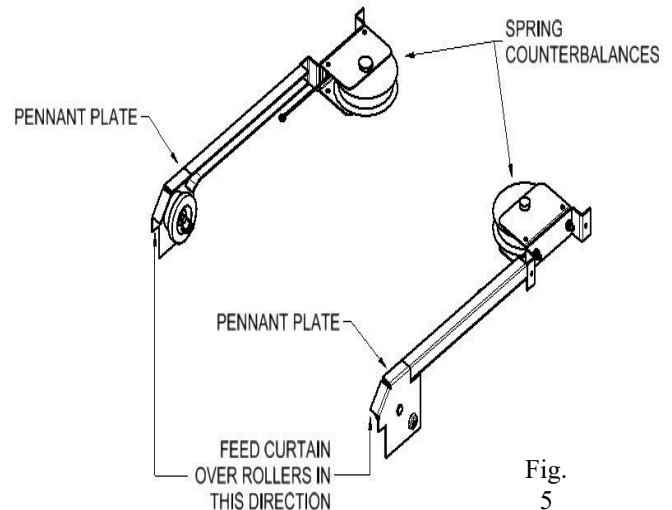

Fig. 5

NOTE: It is important to verify the cable is parallel with the counterbalance spool. If the cable retracts at an angle, it could cause the cable to slip out of the spool and bind. Once the cable is secured to the shutter, cut and remove the rubber sleeve from the cable.

7. Attaching the Strike Blocks

If holes were not pre-drilled, mount the bottom of the strike block flush with the track for standard bottom rail (Fig. 6). Match drill two 3/16" holes, then using the rivets provided pop rivet the strike block to the track. If a door ajar switch system is required drill a 1/2" hole for feeding the wire through located 17/32" below the top mounting hole. All holes should be free of any burrs.

Without Door Ajar Switch (D.A.S.)

- a) Pop rivet strike blocks to the track.

With Door Ajar Switch (D.A.S.)

- a) Install the switch on the appropriate side of track; feed the wires through the middle hole by sliding the 3-inch length of sleeve toward the free ends of the wires, leaving the sleeve on the wires. Insert the 3-inch sleeve halfway through the D shaped hole. While holding the sleeve in that position, pull the wires through it to prevent scaring the wire insulation. After the switch is installed, slide the sleeve to the location where the wires exit the track. It is suggested that a "repair loop" of wire be retained in the track by forming the wires into a compressed "Z" shape. The switch wiring can exit the wire relief on the top or the bottom of the track (see additional instructions when running thru the door frame).

Note: Clay rope or tape can be installed to help hold the wire in the track during installation.

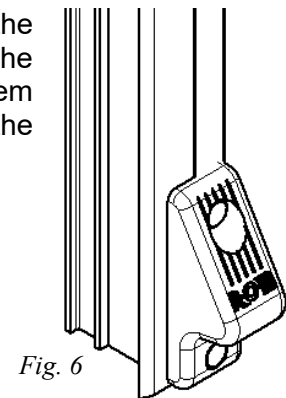

Fig. 6

R•O•M - Series IV MHS Shutter Installation Instructions



Running the wiring through the door frame

- Drill ½" hole in door frame to route the wires through at the same height as the wires on the track, the hole should be free of burrs. Then, place the track into position making sure the protective sleeve is positioned to protect the wires when pulling through.
- Pop rivet the second strike block or second door ajar switch on the opposite track.
- Go to step 8 if compartment lighting has been ordered. Then, wire the switch using the wiring diagrams provided in Fig. 7a or 7b.
- Turn on the power and check the system for proper function.

R03995 - 3 WIRE DOOR AJAR SWITCH WIRING DIAGRAM

Please carefully follow these instructions!
Maximum load on the switch is ½ amp.
Follow the color codes.

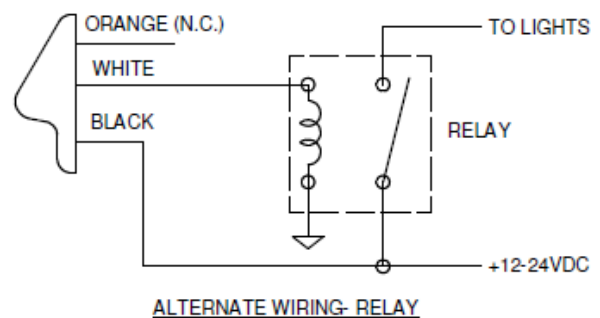
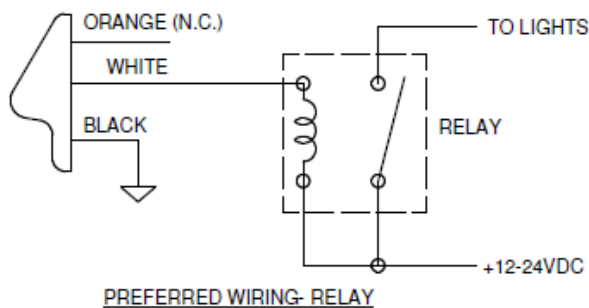
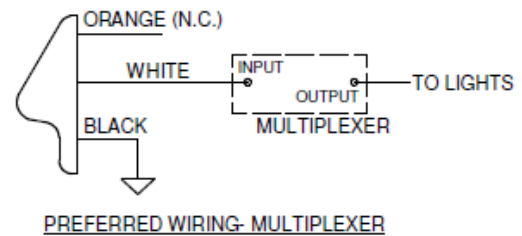

Fig. 7a

Wiring Test Procedure:

NOTE: The Series IV Door Ajar Switch is rated for 1/2 AMP. Control of higher current must be through a relay or multiplexer.

To determine if proper installation has been achieved, check the operation of the door ajar switch by applying a magnet (R•O•M Part # R00011 or any strong magnet) to the door ajar switch where the lift bar rests when the door is closed. When the door is open the compartment light should be illuminated. Therefore, when the magnet makes contact with the door ajar switch the light should turn off. If the compartment light remains on when the magnet makes contact with the door ajar switch, reverse the white and orange wire connections, and repeat the above procedure. If proper operation is still not achieved, re-check the wiring connections for proper wiring.

R•O•M - Series IV MHS Shutter Installation Instructions



R00781 - 5 WIRE DOOR AJAR SWITCH WIRING DIAGRAM

(Preferred Wiring)

Lights to Ground Thru Solid State
Switch Configuration
Indicator Lights to +12-24 VDC 8 Amps Max
(Supply voltage of less than 11V can
cause switch to malfunction)

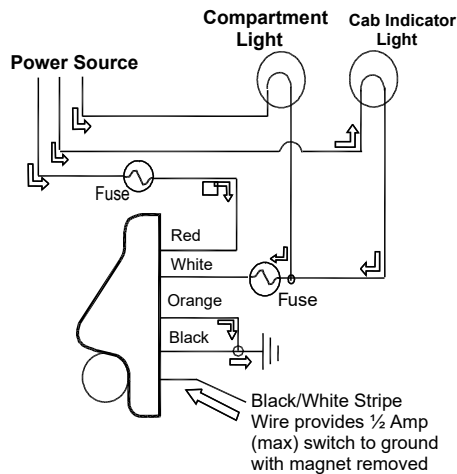

Lights to Power Thru Solid State
Switch Configuration
Indicator Lights to Ground
(Supply voltage of less than 9V can
cause switch to malfunction)

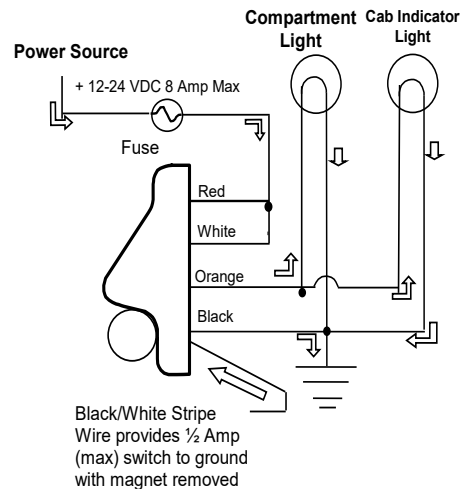

Fig.7b

Wiring Test Procedure:

This device has a solid-state output switch, and polarity is important. Damage to the device may result from extended operation with improper connection of the wires.

To determine if proper installation has been achieved, check the operation of the door ajar switch by applying a magnet (R•O•M Part # R00011 or any strong magnet) to the door ajar switch where the lift bar rests when the door is closed. When the door is open the compartment light should be illuminated. Therefore, when the magnet makes contact with the door ajar switch the light should turn off. If the compartment light remains on when the magnet makes contact with the door ajar switch, reverse the white and orange wire connections, and repeat the above procedure. If proper operation is still not achieved, re-check the wiring connections for proper wiring.

Optional Output

The new switch design has a single output that can be split to provide power to both compartment lights and a door ajar indicator light in the cab of the vehicle. If you have multiple indicator lights in the cab that show which door is open, the new design will work with no additional components or modifications. This can be performed using the black wire with white strip wired directly to the light; unless the current draw is more than a 1/2 amp then it will be necessary to use this wire to provide a controlled ground for an optional relay or electronic control provided by user.

R•O•M - Series IV MHS Shutter Installation Instructions



8. DuroStrip™ LED Compartment Lighting (optional)

Reference FM-8.5-406 - DuroStrip™ V5 Lighting Installation Instructions.

9. Installing the Power Lock (Optional)

- Mount the power lock to the track if not factory installed. The track will be pre-drilled and slotted for the power lock. Mount the lock with 3/16" pop rivets (Fig. 9). Recessed track will have mounting brackets for the power lock to be mounted to.
- Ensure the lock pawl moves freely after mounting.
- Mount the control module so that it is out of the way, mounting it just behind the track is recommended. Route the power lock wires to the power door control module using care to protect the wires. Connect the light green and orange wire from the power lock to the light green and orange wire on the power door control module. If two locks are used connect all wires together. See wiring diagram below.

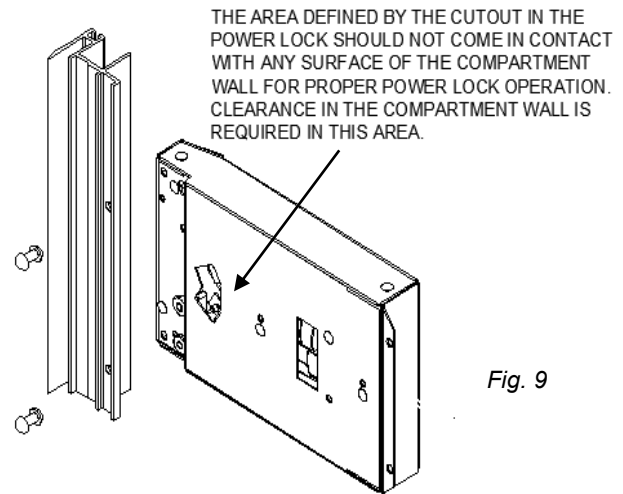
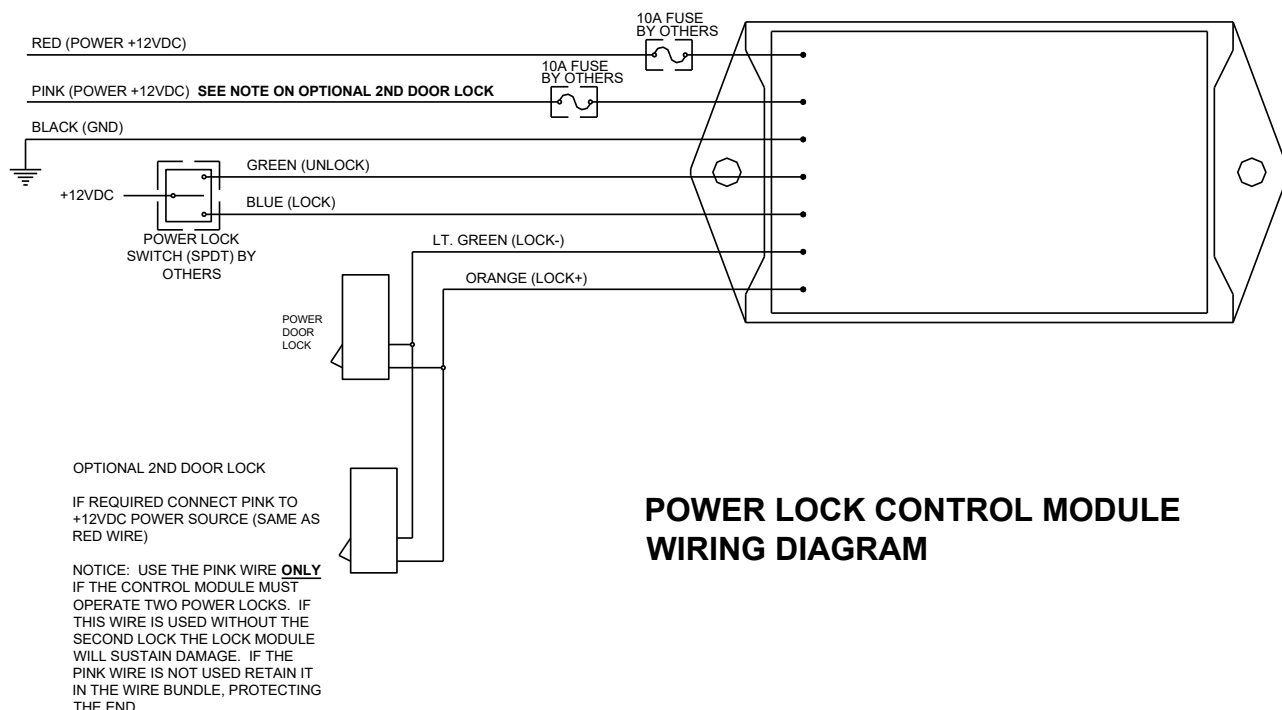

Fig. 9



R•O•M - Series IV MHS Shutter Installation Instructions



Manual Override information:

- a) Manual Unlock: Ensure the door can be manually unlocked when locked by the power lock. The power lock can be bypassed during power or lock failure by turning the key to the unlocked position. The key may be turned to the lock position after the door is raised about 1/2". The door will automatically lock when the door is lowered.
- b) Manually locking the power locks: The power locks maybe manually actuated from the unlocked position to the locked position in case of vehicle power failure. This procedure should only be completed if the lock pawl is not visible in the track after actuating the lock switch to the "lock" position and the compartment must be immediately locked. Two small holes are located in the power lock component. Insert a small straight screwdriver about 1" into the lower hole. Angle the screwdriver so the end inserted into the lock is further away from the door track. Carefully pry the lock pawl forward until it extends into the track opening. The door will automatically lock on the pawl when the door is lowered and can now be locked and unlocked with the key until power is restored.

10. Attaching the Weather-Stripping

- a) To locate the correct position for the weather-stripping (bulb seal), use one track as a guide.
- b) Pull slat assembly down to the threshold and mark position of door to the header.
- c) Remove track, then pull the door down past marked location (if necessary, lock operator with a 16-penny nail to hold position).
- a) Clean the appropriate slat with a 50/50 isopropyl alcohol and water mixture. Let Dry. Attach bulb seal (weather-stripping) to door with the 'fin' of the extrusion on top so that when door is closed it will create a seal between header and slat assembly (see figure 11 option A).

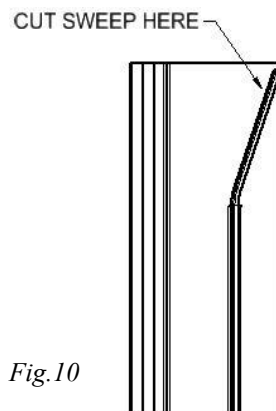

Note: If the door operation (closing and opening) is difficult due the weather-stripping binding too tightly against the back of the header when closed, increase the distance between the slat assembly and the header by incrementally cutting the sweep on back of the track (Fig. 10). Do not cut more than 1/2".

R•O•M - Series IV MHS Shutter Installation Instructions



11. Attaching the Track

- While tilting the bottom rail outward slide the track on it.

Note: Door Ajar wires are easily damaged unless they are correctly tucked into the track.

- Slide the track into place.
- Rotate the track toward the vehicle body and attach with the recommended fasteners.
- To create a watertight opening, use a silicone sealant to seal between the track, sill plate (optional), and compartment. Silicone sealant can also be applied under the strike block or DASS and around the bottom of the track if it does not seat properly with the bottom of the compartment opening.
- The side seal nearest the sill plate should be trimmed so that it is flush with the sill plate. Be careful not to cut the seal too short, this will allow water to enter at this location.
- Shipped loose with your shutter was a label with lubrication instructions. Please place it so that the end user can see it when the compartment is full of equipment.

12. Attaching the Drip Rail (Optional)

- Center the drip rail/top seal in the compartment opening flush against the header. The ends should be even with the outer finishing flange on the track (Fig. 11).
- Remove the excess top seal by cutting the ends to fit between the side seals.
- Mount the drip rail to the header using the recommended screws previously discussed. Be sure that the fasteners do not interfere with the operation of the shutter or cut the weather stripping.
- Using a soft rubber mallet or protective cloth and metal hammer, tap the snap cover into place. Then tap both end caps onto either end of the drip rail.

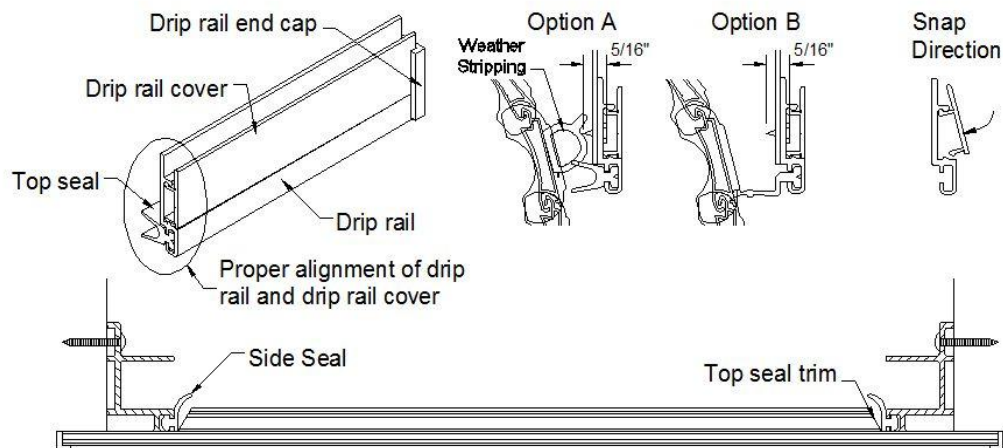

Fig. 11

13. Installing the Pull Strap (optional)

Refer to FM-8.5-385 Elastic Pull Strap Installation Instructions.

R•O•M - Series IV MHS Shutter Installation Instructions



14. Testing Door Operation

Open the shutter by pulling the lift bar out past the strike blocks and up. When closing the shutter, use the finger pull at the top of the bottom rail, rather than the lift bar.

15. Testing Interior Release Operation (optional):

Unlock the manual keylock if equipped. From inside the compartment, close the shutter. To open the shutter from inside the compartment, push down on the push bar and the shutter will unlatch from the door ajar switch/strike block. The push bar can then be used to raise the shutter (Fig. 13).

Note: The internal release only works with the shutter keylock in the unlocked position.

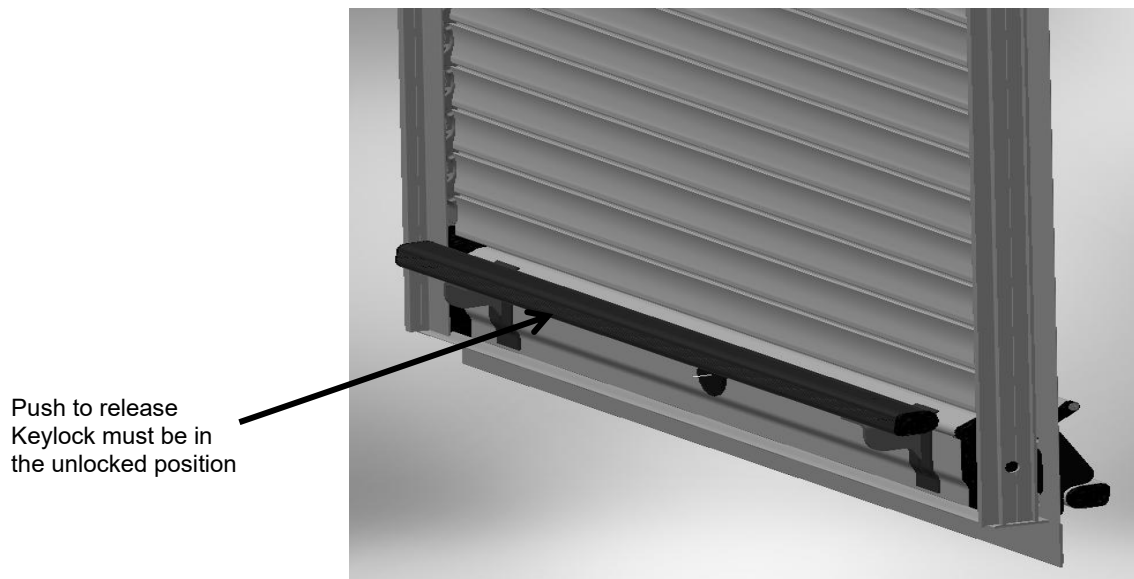

Fig. 13

Note:

This shutter is virtually maintenance free. Periodically check the shutter for smooth operation. If the door becomes difficult to operate, check the track for proper alignment, tighten fasteners, and clean the track. See the Appendix for more information on maintenance.

Do not use oil or grease of any kind on this product. If lubrication is required, a dry silicone spray (non-petroleum based) is recommended.

If you have any questions or issues, please contact your R•O•M Customer Development Representative at 800-827-3692 ext. 5000.

These drawings and the information contained herein are the confidential and proprietary intellectual property of R•O•M Corporation and should not be disclosed to any third party without the express prior written consent R•O•M.

R•O•M - Series IV MHS Shutter Installation Instructions



POWER LOCK DIAGNOSTIC INFORMATION

Power Locks Only

* For the M4000 Power Roll-up Door with a Power Lock Diagnostics please refer to FM-8.5-4000

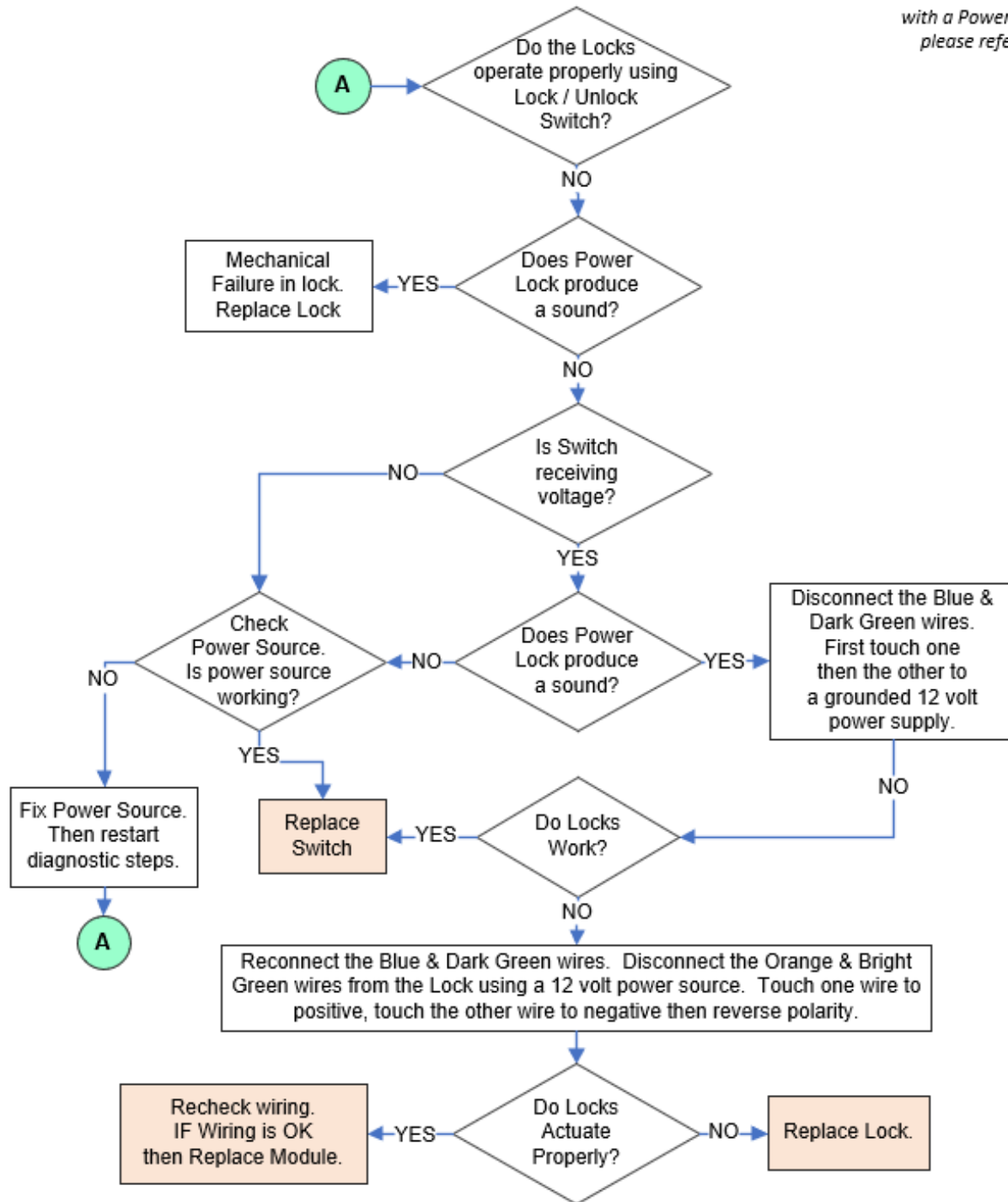

R•O•M - Series IV MHS Shutter Installation Instructions



R•O•M Roll-up Door Series IV – MHS Assembly Drawing R04078

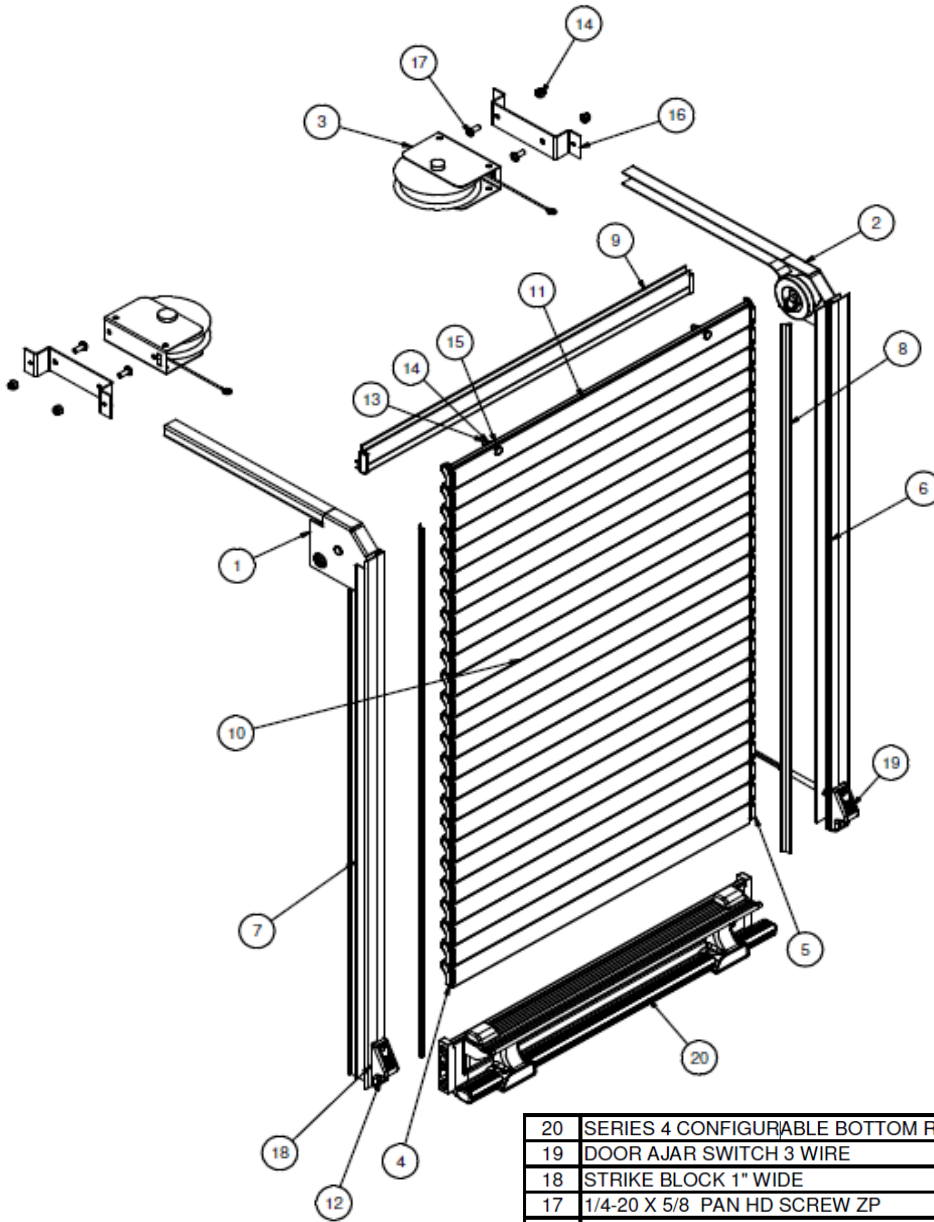

COUNTERBALANCE	
PART NO.	DESCRIPTION
R03271	SPRING COUNTERBALANCE 8 LB CABLE
R03272	SPRING COUNTERBALANCE 10 LB CABLE
R03337	SPRING COUNTERBALANCE 4 LB CABLE
R03338	SPRING COUNTERBALANCE 6 LB CABLE
R03339	SPRING COUNTERBALANCE 12 LB CABLE
R03340	SPRING COUNTERBALANCE 14 LB CABLE
R03341	SPRING COUNTERBALANCE 16 LB CABLE
R03342	SPRING COUNTERBALANCE 18 LB CABLE
R03343	SPRING COUNTERBALANCE 20 LB CABLE
R03344	SPRING COUNTERBALANCE 22 LB CABLE
R03345	SPRING COUNTERBALANCE 24 LB CABLE
R03346	SPRING COUNTERBALANCE 26 LB CABLE
R03347	SPRING COUNTERBALANCE 28 LB CABLE

20	SERIES 4 CONFIGURABLE BOTTOM RAIL	YES	R04024	1
19	DOOR AJAR SWITCH 3 WIRE	YES	R03995	1
18	STRIKE BLOCK 1" WIDE	YES	R03996	1
17	1/4-20 X 5/8 PAN HD SCREW ZP	YES	R02017	4
16	COUNTERBALANCE MOUNT CHANNEL	YES	R03877	2
15	WASHER 1/4 SAE 1/16X9/32IDX5/8OD ZP	YES	10030	2
14	1/4-20 NYL INS STOP NUT ZP	YES	10021	6
13	1/4-20 X 1 HEX HD CAP SCREW GR5 ZP	YES	10016	2
12	RIVET BLIND ALL ALUM 3/16 X .575 CSK	YES	R00091	4
11	TOP SLAT, MHS	YES	R01030	1
10	SLAT ASSEMBLY	YES	R00072	VAR
9	DRIP RAIL ASSEMBLY CFG (REPLACEMENT PARTS)	YES	R00038	1
8	SIDE SEAL LOW PROFILE	YES	R03993	2
7	TRACK, LEFT MACHINED	YES	VARIES	1
6	TRACK, RIGHT MACHINED	YES	VARIES	1
5	RIGHT HAND SHORT END BLOCK	YES	R00635	1
4	LEFT HAND SHORT END BLOCK	YES	R00636	1
3	SPRING COUNTERBALANCE XX LB CABLE	YES	TABLE	2
2	PENNANT PLATE ASSY, RH, MHS	YES	R01028	1
1	PENNANT PLATE ASSY, LH, MHS	YES	R01029	1
NO.	DESCRIPTION	SELLABLE	ITEM	QTY.

R•O•M - Series IV MHS Shutter Installation Instructions



APPENDIX

CLEANING, MAINTENANCE, AND ADJUSTMENT INSTRUCTIONS

THE R•O•M ROLL-UP SHUTTER DOOR IS MADE OF ANODIZED ALUMINUM.

Anodized aluminum is extremely hard and resistant to abrasion. Anodized aluminum can retain its original appearance indefinitely if you follow a sound cleaning and maintenance program. All surfaces are likely to collect dirt and pollutants over time. In some parts of the country, this soiling happens rather quickly due to the level of pollution and proximity to humid coastal regions.

With frequent cycles of condensation and drying as experienced in a humid coastal region, salts and pollutants build up very quickly on exterior surfaces. Contaminations in recessed areas that are not exposed to the washing effect of rain also build up more quickly. These soils can become more and more concentrated as they go through cycles of re-wetting and drying. Eventually mild acid pollutants become harsh acid pollutants. These strong acids can attack aluminum causing a pitting type of corrosion. It is important to begin a cleaning maintenance program as soon as you receive your vehicle to prevent soil build-up.

I. CLEANING AND MAINTENANCE

The R•O•M Roll-up Shutter Door needs very little maintenance, and cleaning is very simple. To wash the anodized shutter slats, use a mix of water and mild soap or detergent with a PH range between 6 and 9, such as Ivory Liquid, Joy, Lux Liquid, or Dove Liquid. This should be performed without the aid of a high-pressure sprayer.

A 50/50 isopropyl alcohol and water mixture is recommended for cleaning anodized slats prior to applying decals and for cleaning the weather-stripping (bulb seal).

If your R•O•M Roll-up Shutter Door has been finished with a polyurethane solvent-based paint, then it needs to be cured according to the paint manufacturers recommendation. All solvent-based paints require several weeks to fully cure and harden depending on temperature and humidity. All washing should be performed using a mix of water and mild soap or detergent, without the aid of a high-pressure sprayer.

The tracks should be frequently cleaned to get the best performance and longest life. To clean the track, use a mild soap and water to remove any dirt or grime build-up. Spraying the tracks with dry (non-petroleum based) silicone is recommended, this will enhance the smooth opening and closing of the shutter. Do not use any type of petroleum-based lubricant in the tracks, this only attracts dirt and grime and creates an abrasive surface, making it hard to operate the door thus shortening the shutter life.

The lift bar should move freely when pulled out and when released should snap back to its rest position.

R•O•M - Series IV MHS Shutter Installation Instructions



Cleaning the Friction Areas

In the operation of the shutter there are friction areas that will need to be cleaned. After cleaning these points, they need sprayed with dry silicone to increase the ease of operation.
(*Never use lithium or grease*)

The friction areas on the shutter are as follows:

1. The pennant plates where the end shoes rub against them
2. The roller that the end shoes roll on
3. The nylon end shoes
4. Inside the side track channels
5. The back side of the rubber side seal
6. Outside of the pivot block
7. The drip rail seal at the top of the opening.

Note: If the drip rail is rubbing against the shutter, the drip rail seal can be trimmed.
However, excessive trimming may allow weather and dust to infiltrate the compartment.

II. OPERATING ADJUSTMENTS

The R•O•M MHS Shutter model does not allow for spring tension adjustment in the spring counterbalances.

However, there are a few things that can be checked that can affect tension when operating the door; these are listed below:

1. Make sure all screw heads on the pennant plates and track are not protruding, so that the nylon end shoes do not touch the screws during operation.
2. Check the compartment to see if it is square. The door will work much easier if the compartment is square. Ideally the shutter should have $\frac{1}{4}$ " of the total side play when moved laterally at any point. Check the alignment of the pennant plates. They should be parallel and equal distance from the front and bottom of the opening.
3. If the door is difficult to open and close, the shutter may need to be lubricated.

III. SLAT REPLACEMENT

If the R•O•M Roll-up Shutter Door needs slats replaced, they can be replaced with the slats that are non-visible when the curtain is in the closed position. Do not use the first slat closest to the counterbalance for it has been specifically modified to accommodate the hooks (Fig. 4).

R•O•M - Series IV MHS Shutter Installation Instructions



Before you begin

This procedure requires that you lay the curtain and track on its face. Always remember to protect the face of the curtain and any other visible parts.

1. To remove the drip rail assembly, refer to step 11 to see how it was installed.
2. To remove the track assembly, refer to step 10 to see how the track was installed. Remember to remove the sealant used to seal the track. This will ensure that the new sealant will adhere correctly during the track reinstallation.
3. To detach the curtain assembly, refer the step 6 to see how the curtain was attached. Once the curtain assembly has been detached you will need to lay it on its face using a blanket, rug, towel, or any other kind of soft material that will prevent the curtain from being scratched.
4. To remove the end shoes, grasp the middle of the end shoe with a vise grip and twist out until the end shoes slides out of the end of the slat. (Fig 13.)

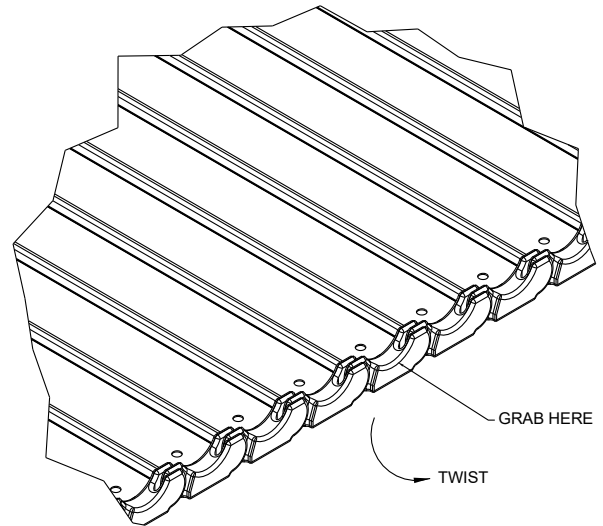

Fig. 13

5. After removing the end shoes on both sides slide out the damaged slat and the hidden slat. Replace the damaged slat with the hidden slat and reassemble.
6. Place one end of the curtain against a back stop. Then, install the end shoes on the opposite side by tapping the end shoes with a small hammer. The end shoes should be tapped in until flush and look like they did prior to taking them off. Rotate the curtain around and repeat.
7. After the slats and end shoes have been replaced, re-install the shutter following steps 6, 10 and 11 of the installation instructions.

If you have any questions or problems, please contact your Customer Development Representative at 800-827-3692 ext. 5000 or rom.orders@romcorp.com.

These drawings and the information contained herein are the confidential & proprietary intellectual property of R•O•M Corporation and should not be disclosed to any third party without the express prior written consent R•O•M.