

## R•O•M DuroStrip™ V5 Red-White LED Lightbar

*Our Technical Bulletins are provided to inform you of design options, design improvements, standard sizes and changes, different models, applications, installation, operation, and maintenance*

Introducing R•O•M's Red / White option to our DuroStrip™ V5 LED compartment lighting line.

- **Effective: 03-01-2026** - R•O•M released our new **DuroStrip™ V5 RED - WHITE** LED Lightbar.

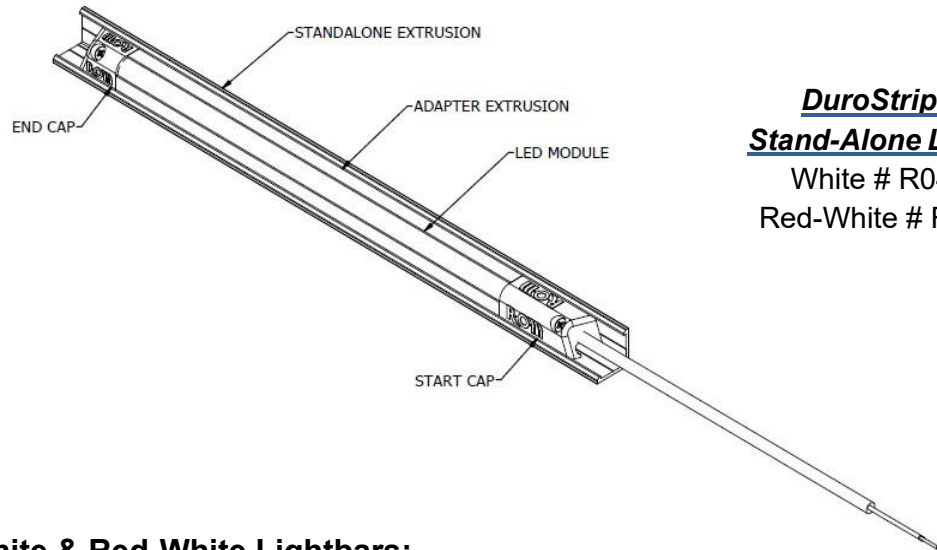

**DuroStrip™ V5**  
**Stand-Alone Lightbar**  
 White # R04786  
 Red-White # R04799

### Features for White & Red-White Lightbars:

- **WHITE LED:** 367 lumens @ ft.  
Draws 0.35 amps @ 12.8 VDC approx. ft. (304mm).
- **RED-WHITE LED:** White has 250 lumens / Red has 60 lumens @ ft  
Draws 0.22 amps @ 12.8 VDC approx. ft. (304mm).
- Extreme Temp Certified operation between -40°F to 185°F (-40°C to 85°C)
- Waterproof design to IP67 rating.
- Exceeds NFPA 1900 standard.
- Streamlined optic lens and fixed lumen output across 9VDC–16VDC.
- Color temperature tolerance to insure color consistency.
- May be “switched to positive” or “switched to negative”.
- Vibration tested to MIL 810 rev A
- Salt Spray - 1,000-hour testing, no corrosion
- Integrated lower profile system is less intrusive and more out of harm's way.
- Stand-alone extrusion is available for mounting in interior/exterior locations.
- Integrates with R•O•M Door Ajar Switch
- LED Modules slide into R•O•M's LED integrated track with securement screw in start and end caps.
- Stand-alone lightbar is available for interior or exterior
- Easily retrofits to replace previous DuroStrip V4 lightbar components.



# Product Advisory

## R•O•M DuroStrip™ V5 Red-White LED Lightbar

### LED V5 Lightbar Lengths available:

6" (152 mm)	12" (304 mm)	18" (457 mm)	24" (609 mm)
30" (762 mm)	42" (1067 mm)	60" (1524 mm)	

### Stand-Alone Lightbar – Mounting options:

- 3M VHB Dual Sided Mounting Tape - Ships with mounting tape loose (*default option*)
- Mounting Slots - Ships with pre-punched slots at both ends (*no tape*)
- Adjustable Mounting Blocks - Ships with mounting blocks loose (*no tape*)

### FAQs:

**Q:** Why is the actual Integrated LED lightbar shorter than door opening height?

**A:** Several variables are taken into consideration when determining available space for LED Integrated lighting. Custom configurations are used to ensure maximized lighting while avoiding interference with locks, roll space and service space.

**Q:** How is the available lighting space calculated for a typical compartment opening?

**A:** The OH (opening height) is the base dimension.

- 2" deduction is typically made for lower track notch area for standard bottom rails without power locks.
- 6" deduction is made for upper track area where the track sweep and notch exist.
- 3-3/4" deduction is made for start and end caps.

This value less all deductions is the available lighting area.

*Example: OH = 40.00"*

*40.00" - 2.00" - 6.00" - 3.75" = 28.25" available lighting area*

Pricing only applies to the actual LED lighting length.

Note: Various shutter configurations may generate different calculations for clearance.

For additional information, please contact R•O•M Customer Service at:  
(800) 827-3692 ext. 5000 or [rom.orders@romcorp.com](mailto:rom.orders@romcorp.com)

**Please provide this information to your engineering, manufacturing,  
sales and marketing departments, and to your dealers.**

*These drawings & the information contained herein are the confidential & proprietary intellectual property of R•O•M and should not be disclosed to any third party without the express prior written consent of R•O•M.*