

SIDEKICK RAMP and CARRIER SYSTEM **INSTALLATION INSTRUCTIONS**

FM-7.5-45
Rev. D
8/6/10

Congratulations on your purchase of the R•O•M Roadwarrior Sidekick Ramp and Carrier System! This system will provide maximum safety and productivity for many years with proper care and maintenance. **Please read and follow these instructions carefully!**

Using the Roadwarrior Sidekick ramp with apron

Ramp apron hooks act as an anchoring device for securing the ramp to trailer deck. These apron hooks come pre-installed at 13 1/2" spacing *Fig. 2* for standard width ramps. Hook spacing may vary for custom width ramps.

Ramp hooks may be relocated when necessary to align with pre-existing receiving holes.

To reposition apron hooks:

Note: Be sure bottom of coupling nut is 3" minimum from the front edge of apron to prevent dragging in the carrier *Fig. 1*. The trailer will need to be modified to accept apron hooks if receiving holes are not present.

1. Remove coupling nuts from carriage bolts using a 5/8" wrench.
2. Select desired apron hook locations only where holes are pre-punched. Re-attach apron hooks as shown in *Fig. 2* and tighten until carriage bolt is pulled snugly against apron.

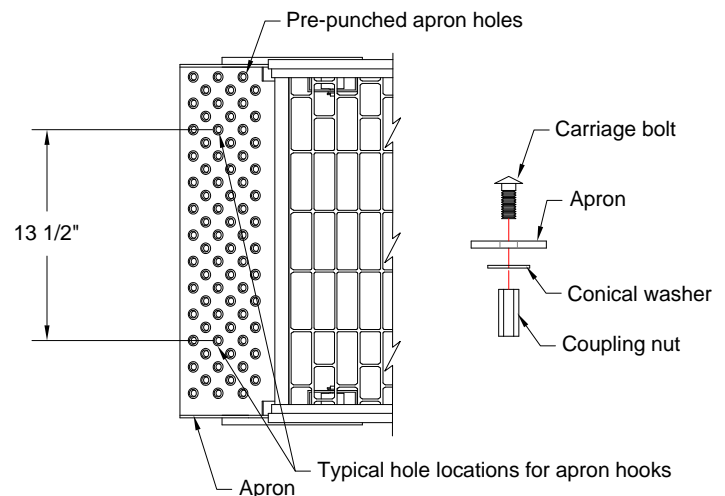
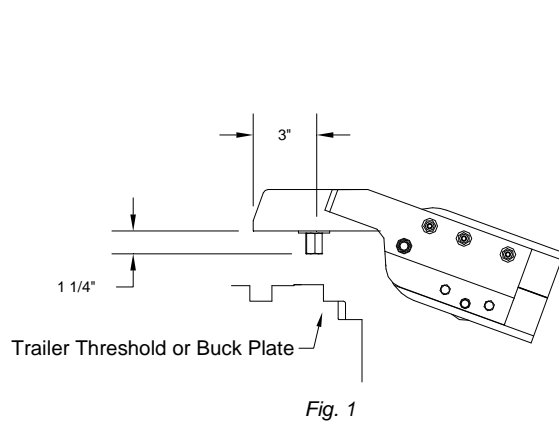

Fig. 2

If (Skip steps 3-5 if trailer apron hook receiving holes already exist)

3. Mark receiving holes by using the apron hooks as a template.
4. Drill a 7/8" diameter minimum hole size at marked locations.
5. Insert apron hooks into associated receiving holes to secure the ramp.

Installing the Roadwarrior Sidekick Ramp Carrier under the Trailer

The Roadwarrior Sidekick Ramp must be used only with its companion R•O•M Sidekick Carrier.

1. Verify all trailer dimensions where the carrier is to be installed:
 - a. The carrier requires 8'-0" length x 32 1/2" width x 12 3/4" height of clearance.
 - b. Carrier must not be mounted in front of landing gear or it will interfere with the trailer's kingpin.
2. Remove the Sidekick ramp and any shipping material from the Roadwarrior Sidekick carrier.
3. Position the carrier in the opening. Assure that the carrier does not protrude beyond the sides of the trailer and there are no obstructions that would prevent proper use of the ramp.
4. The carrier should be attached to the cross members of the body with at least three steel supports around the carrier. It is recommended that the supports be fabricated from 2" steel angle or channel or any other material with sufficient strength to support 350 pounds under all road conditions.
 - a. Trailer with steel framing and cross members: the steel supports can be welded directly to the cross members.
 - b. Trailers with aluminum framing and cross members: bolt the carrier supports to the aluminum members.

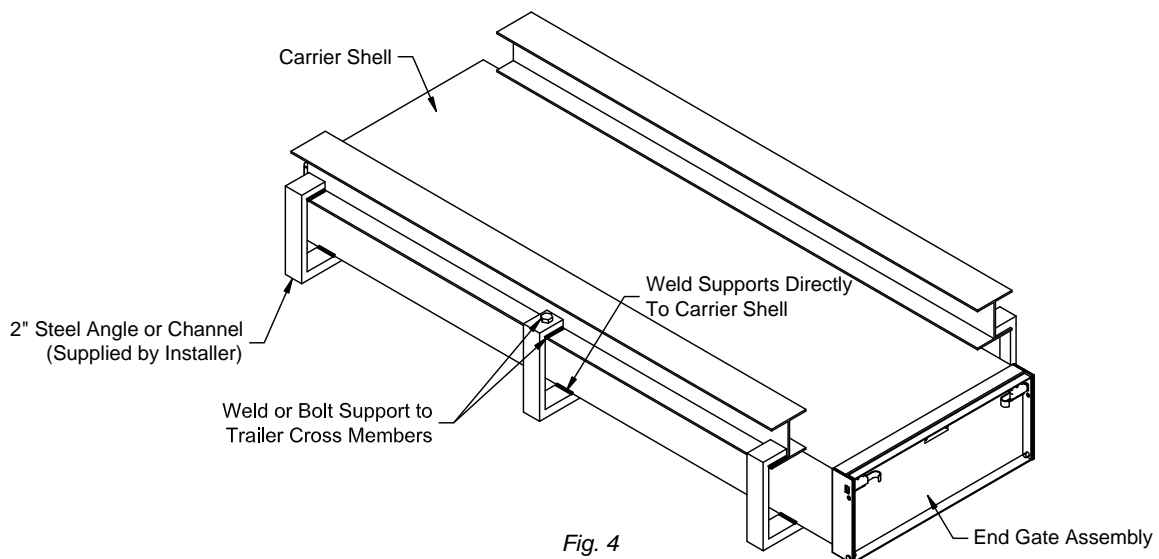

Using the Roadwarrior Sidekick Ramp and Carrier

Our Roadwarrior Sidekick Ramp is designed to fold in half and store transversally under most trailers. To deploy the Sidekick, use the following steps:

1. Unlatch and lower the carrier end gate.
2. Pull out the ramp until the legs have cleared the carrier.
3. Lift legs and flip them away from the carrier. Making sure the legs are securely latched into place.
4. Pull out the rest of the ramp and roll the ramp to desired location
5. Using the ramp hooks, secure the ramp apron to the trailer deck.
6. Lift top portion of the ramp and gently flip away from the trailer, allowing wheels to retract and provide a rigid support for the ramp.
7. Carefully set the end of the ramp on the ground to avoid damage from sudden dropping. See Fig. 6.

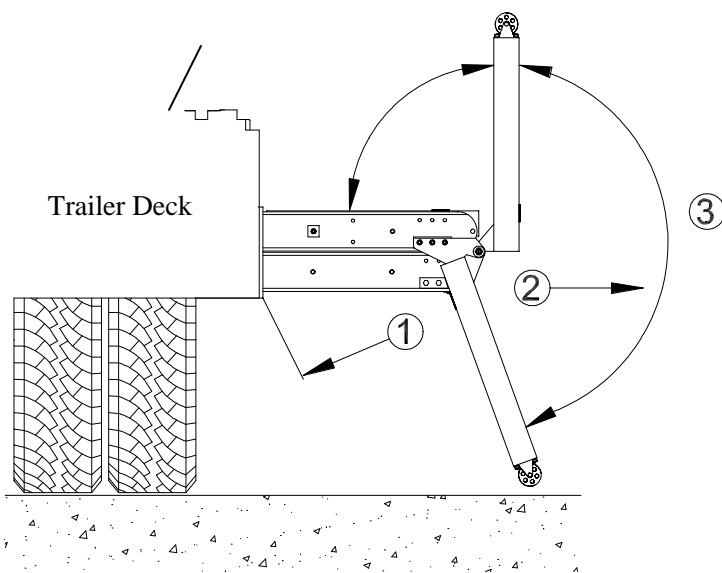

Fig. 5

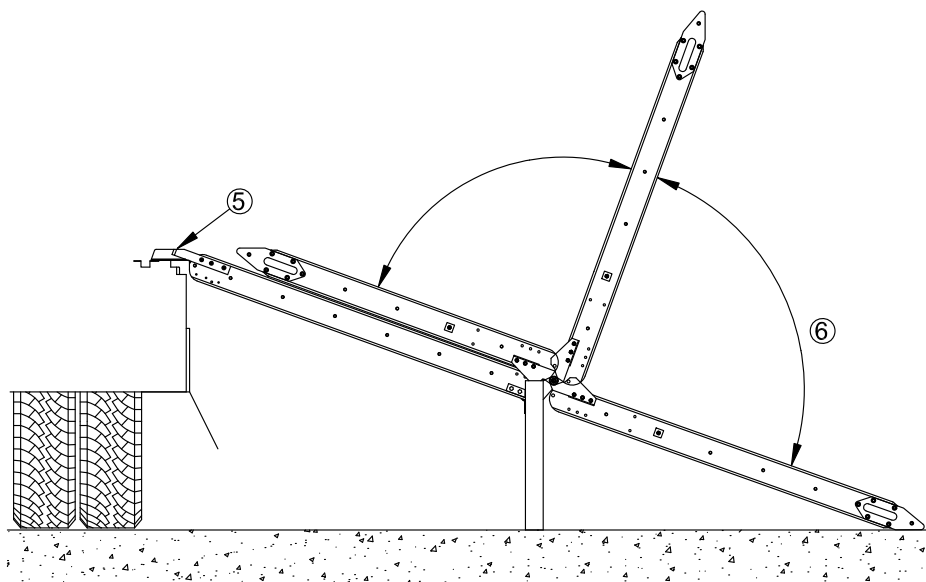
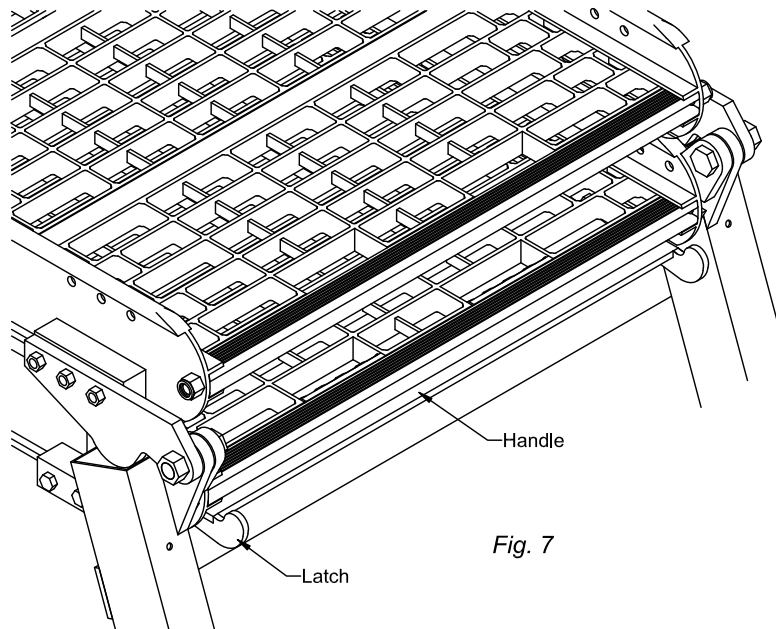

Fig. 6

To stow Sidekick:

1. Lift end of ramp and fold towards trailer.
2. Lift the ramp off of the trailer deck and roll ramp back to carrier.
3. Push ramp carefully into the carrier until ramp is no longer supported by the legs.
4. Lift the handle up until the latches have released, allowing legs to be folded up. See Fig. 7.



5. Lift the legs up and fold towards carrier, gently setting them down onto the ramp.
6. Continue to push in the ramp until the end gate of the carrier may be closed.
7. Close and latch carrier end gate.

For proper care and ramp maintenance please reference FM-7.5-140 Rev. C located on R•O•M's web site at www.romcorp.com. If you have any problems, please call R•O•M Corporation at 1-800-827-3692 or visit our website www.romcorp.com

Copyright © 2010 R•O•M Corporation. All Rights Reserved. These drawings and the information contained herein are the confidential and proprietary intellectual property of R•O•M Corporation and should not be disclosed to any third party without the express prior written consent of R•O•M Corporation.