



## ***SIDESTEP LADDER and CARRIER SYSTEM*** **INSTALLATION INSTRUCTIONS**

---

FM-7.5-04  
Rev. A  
02/21/08

Congratulations on your purchase of the R•O•M SideStep Ladder and Carrier System. This product will provide maximum safety and productivity for many years with proper care and maintenance.

**Please read and follow these instructions carefully!**

### **Using the Ladder**

R•O•M offers securing hooks as a standard feature with every ladder. These hooks act as an anchoring device to secure the ladder to the trailer, as shown in Fig. 1. The hooks come pre-installed and are spaced at a center-to-center distance of 17 1/4" apart. The ladder hooks may be used with the RoadwarriorR Platform or with pre-existing holes or brackets on the trailer. If there are no pre-existing fastening points, the trailer will need to be modified to accommodate the ladder hooks.

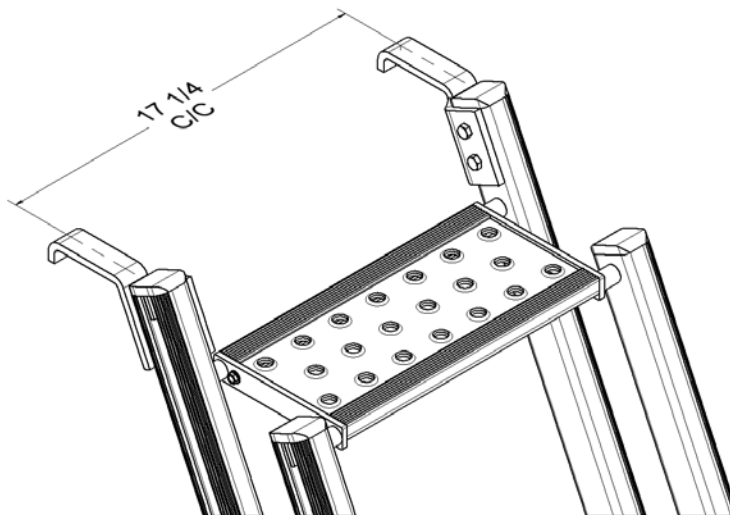

*Fig. 1*

**Follow these safety steps for proper Sidestep Ladder setup and use:**

1. Inspect ladder for loose or worn hardware prior to use.
2. Lean ladder against platform or threshold opening.
3. Engage ladder hooks with platform receiving holes, pre-existing holes or brackets on the trailer.
4. Squeeze ratchet bar and adjust steps until level with the horizontal plane. Release ratchet bar to allow ratchet catch to click into place, as shown in Fig. 2.

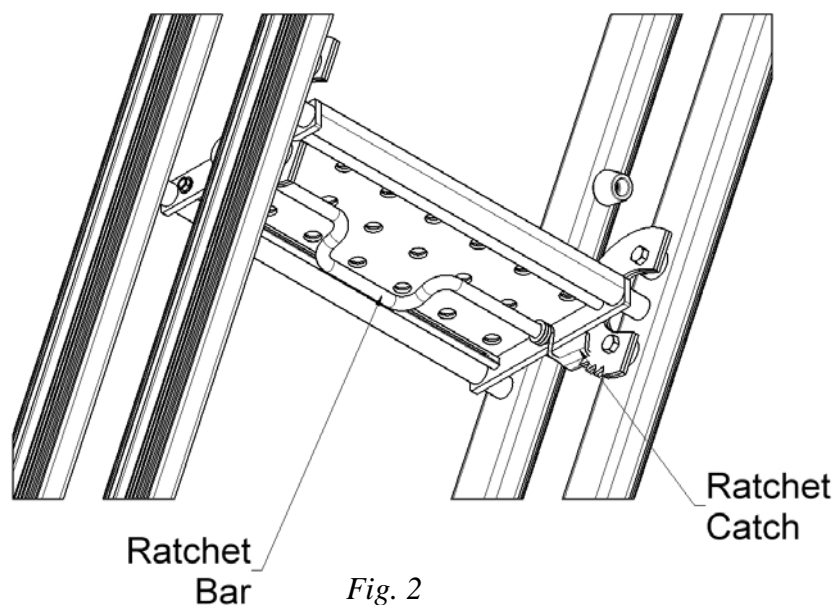

5. Check that both ratchet catches are fully engaged.
6. Always face the ladder with body between the upright rails when using.
7. When stowing the SideStep ladder, lift the outer rails up, collapsing the SideStep. This will lock the ladder in the closed position. Replace in carrier.

Note: The SideStep Ladder is not intended to be used for loading and unloading product.

## **Factory Installed Ramp Hook Positions**

1. After you have determined the proper location to secure the ladder to the trailer floor, use the hooks as a marking template to mark your holes.
2. Install holes or slots per the dimensions shown in Fig. 3 where you have marked.

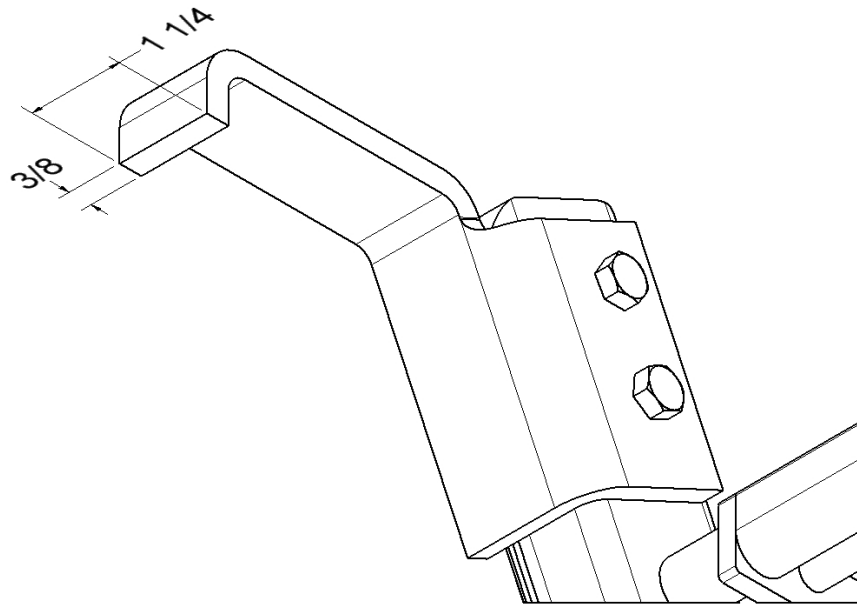

*Fig. 3*

## **Installing the SideStep Ladder Carrier under the Trailer**

Our carrier is designed to store a SideStep Ladder mounted transversally under the trailer. The SideStep carrier is not designed to be used as a resting point for the ladder while it is in use. For safety reasons, it is important that the ladder be secured to the trailer during use. The SideStep Ladder must be used only with its companion R•O•M SideStep Carrier.

1. Verify all trailer dimensions where the carrier is to be installed. The carrier requires 5'-10" length x 21 3/4" width x 12 3/4" height of clearance. Carrier must not be mounted in front of landing gear, or it will interfere with the trailer's kingpin.
2. Remove all packing material from the SideStep carrier.
3. Position the carrier in the opening. Assure that the carrier does not protrude beyond the sides of the trailer, and there are no obstructions that would prevent proper use of the ladder.

4. The carrier should be attached to the cross members of the body with at least three steel supports around the carrier. It is recommended that the supports be fabricated from 2" steel angle or channel, or any other material with sufficient strength to support 175 pounds under all road conditions. Weld supports directly to the carrier shell.

Note: If the trailer body has steel framing and cross members, the steel supports can be welded directly to the cross members. If the trailer body has aluminum framing and cross members, it will be necessary to bolt the carrier supports to the aluminum members.

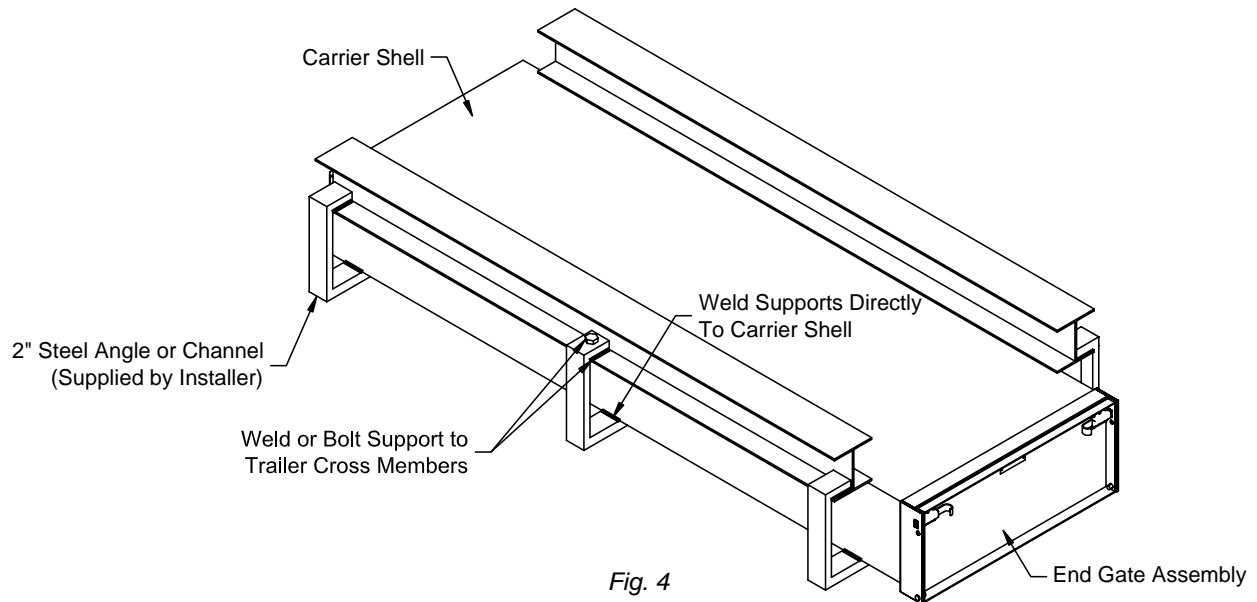

**If you have any problems or for warranty information, please call R•O•M Corporation at 1-800-827-3692 or visit our website [www.romcorp.com](http://www.romcorp.com)**

Copyright © 2008 R•O•M Corporation. All Rights Reserved. These drawings and the information contained herein are the confidential and proprietary intellectual property of R•O•M Corporation and should not be disclosed to any third party without the express prior written consent of R•O•M Corporation.