



Excellence made to order.

6800 East 163<sup>rd</sup> Street  
Belton, MO 64012-5463  
816 318-8000  
1-800-827-3692  
FAX 816-318-8100



## ***R-O-M SHUTTER™ SERIES III QUEST 2000 Power Operator System***

---

**FM-7.5-63**  
**REV. J**  
**10/09/07**

Congratulations on your purchase of the R•O•M Quest 2000 Power Operator & Power Lock system on your ROM Shutter!

### **Please read and carefully follow these instructions!**

You will need the following parts and tools for installing your Power Operator & Power Lock System; please note that these are not included with your system.

- Fasteners for drip rail and track (Self-tapping hex-head #10 machine or sheet metal screws are recommended)
- Drill
- Drill bits-#29, 11/64", 3/16", 3/8", and 1/2"
- Single Pole Double Throw Switches for Door/Lock Input Switches (On)-Off-(On)
- Power Door Lock Switch
- Door Ajar/Compartment White Light
- 10 and 20 Amp Fuse and holder
- Clear indoor/outdoor silicone sealant
- Screwdriver – Phillips
- Wire cutters
- Wire crimp
- Tape measure
- Marking pen
- Pop rivet gun for 3/16" pop rivets
- 5/64" Allen wrench if lighting is required
- Rubber headed mallet
- Paper towels
- Rubbing alcohol
- 7/16" wrench and/or socket
- DC current meter (suggested)
- Wire nuts and/or solderless connector for joining 22 gauge wires to vehicle wiring

**Note:** *Size vehicle wiring to allow 8 amps for each power operator system, if two are running concurrently allow 16 amps, etc...*

For a successful installation of the R•O•M ROM shutter with power operator and lock system, follow these 17 steps:

- 1) Unpacking
- 2) Pre-drilling holes
- 3) Attaching the sill plate
- 4) Attaching the pennant plates
- 5) Prepare motor assembly and extension shaft
- 6) Installing the motor assembly and extension shaft
- 7) Installing the power door control module
- 8) Installing the operator and door curtain
- 9) Installing the power lock
- 10) Installing the door ajar/compartment light sensor
- 11) Attaching the track
- 12) Adjustable compartment lighting
- 13) Attaching the drip rail
- 14) Installing the drip pan
- 15) Installing the drain hose
- 16) Control module wiring, door and lock test
- 17) Manual override information

## 1. Unpacking

- a) Unpack and carefully lay out all of the parts. The shutter should be unrolled on a smooth, clean surface to prevent scratching the finish on the slats.
- b) Make sure all parts shown on the assembly drawing on page 13 are included.
- c) Handle the electrical components carefully especially wiring coming off the control modules.

## 2. Pre-Drilling Holes

**If your process involves pre-drilling all the holes in body prior to the finishing operation, follow these steps. If you do not pre-drill the holes, they must be drilled as you install the components.**

### **Pre-drilling with templates**

- a) If pre-drilling with templates; drill holes for track, pennant plates, and drip rail at this time.

### **Pre-drilling using door parts**

- a) Looking into the compartment, place the pennant plate with the right hand pennant plate label in the top right of the compartment as shown in Fig. 1. Make sure it is flush with the top of the compartment and 1-5/8" from the vehicle skin.
- b) Match drill four 11/64" holes for each pennant plate.
- c) Position the track between the header and the bottom of the compartment. Make sure the bottom of the track touches the bottom of the compartment. (Fig. 2) The finishing flange should be flush against the skin of the vehicle.

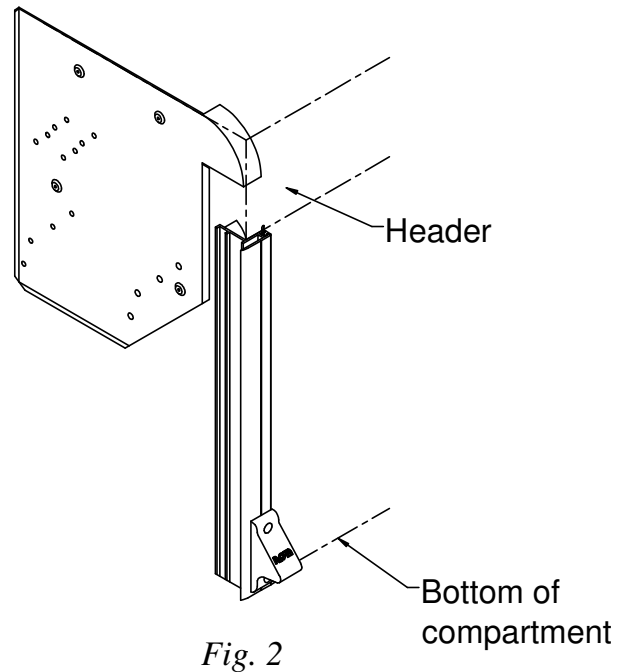
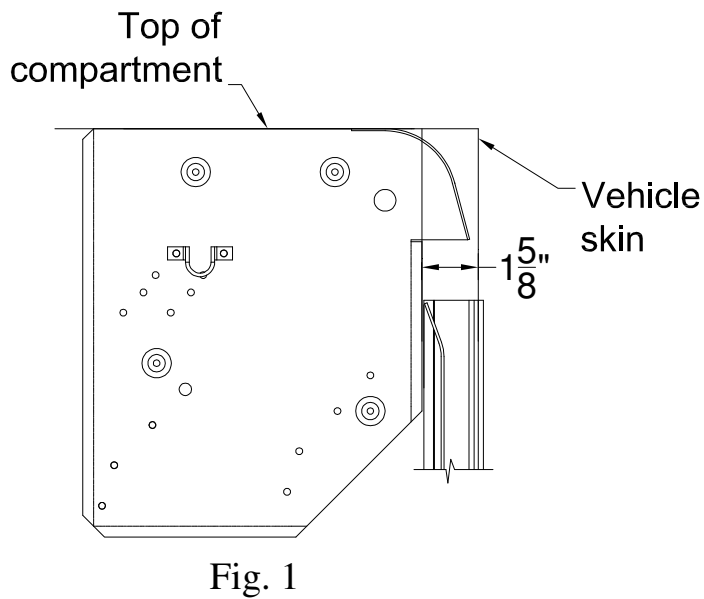

**Note:** If the sill plate option is included, place the track on the sill plate or 1/8" up from the bottom of the compartment prior to drilling.

- d) If pre-drilled track was ordered. Match drill 11/64" holes in the vehicle body where holes are present in the track.
- e) Center the base section of the drip rail/top seal in the compartment opening flush against the header. The ends should be even with the outer finishing flange on the track.
- f) Drill holes in the drip rail where necessary for attachment. The maximum fastener length should be 5/16". A hex head fastener is recommended for easy removal of the drip rail. Use the centering groove on the drip rail to hide the fastener after the drip rail facing has been attached.

**Do not attach drip rail until step 13!**

### 3. Attaching the Sill Plate (Optional)

- a) Place the sill plate in the center of the bottom compartment. The notches should be on the top of the bottom compartment (Fig. 3).
- b) Make sure the bottom of the compartment is clean then remove the backing from the tape on the sill plate and attach.

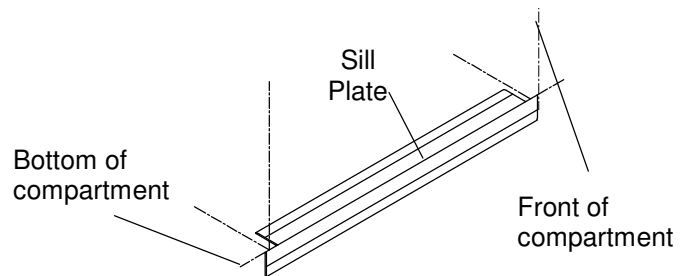

*Fig. 3*

#### 4. Attaching the Pennant Plates

- a) Mount the right and left side pennant plates assuring the bushings are installed from far side.

#### 5. Prepare Motor Assembly and Extension Shaft

- a) Check and record the distance of the internal width. This measurement is necessary to ensure the proper fit of the motor and extension shaft assembly.
- b) Place the sprocket on the end of the extension shaft placing the roll pin in the slot on the drive sprocket.
- c) Using the three-piece coupling assemble the extension shaft to the motor, making sure the drive lobes of the drive sockets are orientated in the position.
- d) Tighten one of the setscrews, leaving the other one loose until the assembly is installed. Check the total shaft length. The combined length should be 1/4" shorter than the measured internal width (see Fig. 4).
- e) If the shaft length is too long, remove material on the extension shaft where the coupling is mounted to make it the acceptable length.

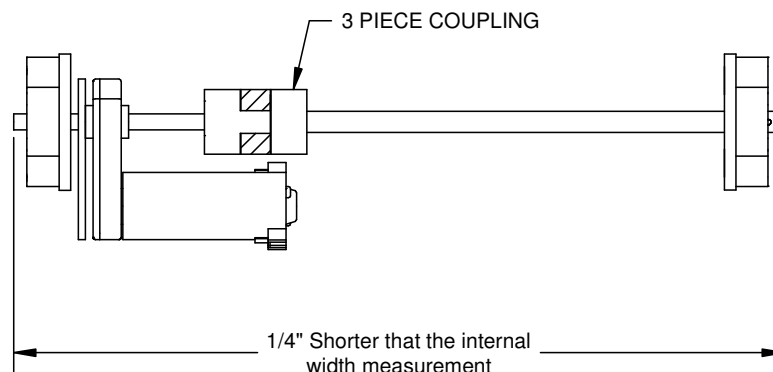

Fig. 4

#### 6. Installing the Motor Assembly and Extension Shaft

- a) Insert the motor shaft into the bushing on the left pennant plate. Align the extension shaft with the bushing on the right pennant plate and push the two shafts toward the two pennant plates, install the flexible spider between the shaft couplings and tighten the setscrews.
- b) Using three 1/4-20 x 1/2" hex head screws bolt the motor assembly to the left pennant plate.

- c) Check shaft endplay. There should be approximately 1/16" endplay, but no more than 1/8". Excessive endplay could allow the shaft to move and fall out of the pennant plates.
- d) Recheck the location of the two sprockets to ensure the drive lugs are aligned with each other. Alignment can also be checked with the alignment holes on the sprocket; reference fig. 5.

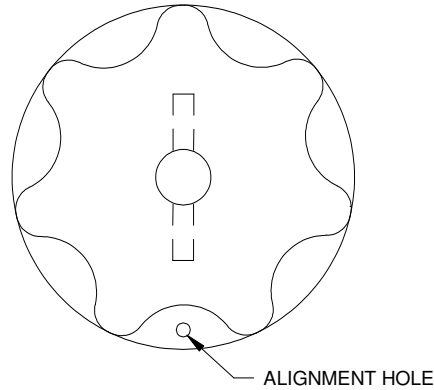

Fig. 5

**7. Installing the Power Door Control Module** (Reference wiring diagram on page 11)

- a) Connect the gray wire from the power door control module and connect it to the terminal on the motor that is identified by a "+" on the motor face. Connect the brown wire to the other motor terminal.
- b) Install the power door control module to the left side near the pennant plate.

**8. Install the Operator and Door Curtain**

- a) Place the operator shaft into the U-Brackets on the pennant plates. The tension pin and label shall be on the right while looking into the compartment as shown in Fig. 6

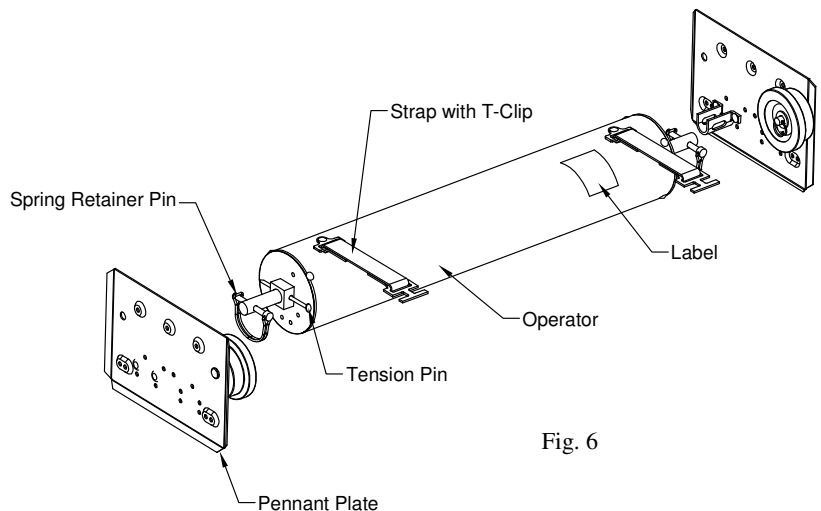

Fig. 6

- b) The straps should wrap around the operator diameter approximately 1-1/4 times, then drape down approximately 5".

- c) Insert the spring retainer pin.

- d) Feed the top slat of the shutter on top of the sprockets. It will be necessary to drive the motor and gearbox manually in order to feed the curtain into the compartment. Let the curtain hang behind the operator. With the curtain in this position place the T-clip into the slots on the top slates and secure. Do not force, lift or lower the curtain quickly or slam it

slam it against the stops at the top or bottom. Damage to the motor gear train will result if the gear motor is not allowed time to rotate. It is possible to attach a temporary 12 VDC power to the motor's "+" terminal to drive the motor around to install the curtain. You will have to remove the gray and brown wires previously installed to do this.

- e) After the curtain is installed, slightly rotate the operator clockwise and remove the tension pin (nail). Reverse the rotation and slowly roll shutter around operator, so the bumpers on the bottom rail touch the header.

## 9. Installing the Power Lock

- a) Mount the power lock to the track if not factory installed. The track will be pre-drilled and slotted for the power lock. Mount the lock using 3/16" pop rivets (Fig. 7). Recessed track will have mounting brackets for the power lock to be mounted to.
- b) Ensure the lock pawl moves freely after mounting.
- c) Route the power lock wires to the power door control module using care to protect the wires. Connect the light green and orange wire from the power lock to the light green and orange wire on the power door control module. If two locks are used connect all wires together.

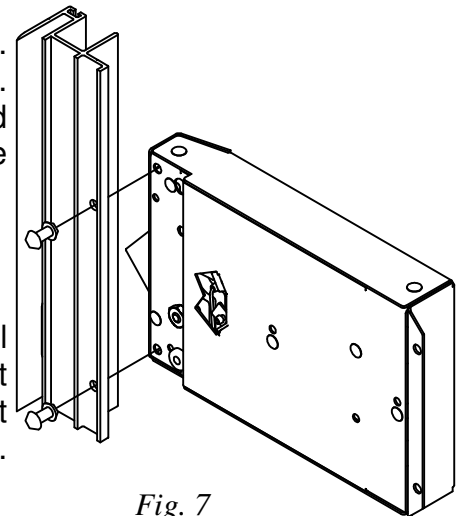

Fig. 7

## 10. Installing the Proximity Switch

- a) Place the end of curtain travel proximity switch 2 3/4" from the top of the track to the bottom of the switch and 2 3/4" from the bottom of track to the top of the proximity switch. This distance should be increased to 3 1/4" when a bottom rail extension is used and 4 1/4" for the tall bottom rail. See Fig. 13 for an example of where the proximity switch is located with conventional track. Temporarily install the switch in the track with silicone or some other temporary substance.

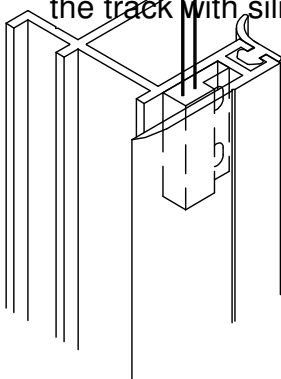

Fig. 13

- b) The proximity switch is normally open. When the magnet on the bottom rail passes over it while opening or closing the door it signals the power module to shut the power off to the motor. The signal from this switch can also be used to provide power to the door ajar/compartment light switch provided by others (see wiring diagram-white wire). With this being known, connect the compartment light and power to the control module temporarily install the track and test this function. If the light fails to turn on when the door opens the proximity switch will need to be adjusted. Use silicone to permanently secure the

Use silicone to permanently secure the proximity switch to the track.

## 11. Attaching the Track

- a) While tilting the bottom rail outward slide the track onto it.
- b) Rotate the track toward the vehicle body and attach with the recommended fasteners, including the installed power lock.
- c) To create a watertight opening, use a silicone sealant to seal between the track, sill plate (optional), and compartment. Silicone sealant can also be applied around the bottom of the track if it does not seat properly with the bottom of the compartment opening.
- d) The side seal nearest the sill plate should be trimmed so that it is flush with the sill plate. Be careful not to cut the seal to short, this will allow water to enter at this location.
- e) To create a watertight opening, use a silicone sealant to seal between the track, high water seal plate and compartment.
- f) Shipped loose with your shutter is a label with lubrication instructions. Please place it so that the end user can see it when the compartment is full of equipment.

## 12. **Adjustable Compartment Lighting (optional)**

**NOTE:** *DO NOT ALLOW THE HALOGEN LAMPS TO COME INTO CONTACT WITH BARE SKIN. THE LAMPS WILL BE VERY HOT AFTER OPERATION, AND THE OILS FROM HUMAN SKIN SIGNIFICANTLY REDUCE THE LIFE OF THE LAMP. IF CONTACT WITH SKIN IS MADE, CLEAN THE COOLED LAMP WITH A SOFT PAPER TOWEL AND RUBBING ALCOHOL.*

- a) Determine the path the wires will be routed (top or bottom exit, LED light strips are ordered with wiring out a specified end). Ensure that there are no sharp edges that could cut through the wire insulation.
- b) To install plastic end caps, first use a ballpoint pen tip or a nail to puncture the area shown in the end cap to be used for the electrical connection. See Figure 11. Feed the short wire lead from the inside of the end cap to be used. All wire connectors should remain inside the light assembly when the end caps are installed.
- c) Attach the red wire to the power source wire and the black wire to the body of the vehicle for a ground. Using a connector of your choice.
- d) For halogen light bars verify that the lamps are in the appropriate locations to provide optimum illumination. If they are not, simply slide the socket shown in fig. 8 to the desired location.

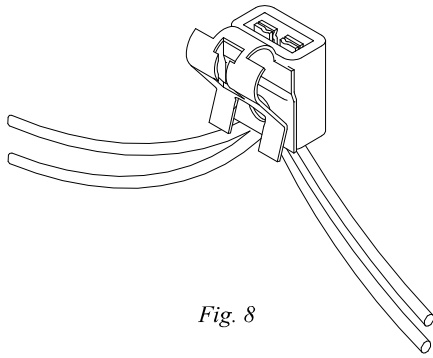

Fig. 8

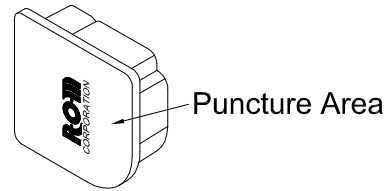

Fig. 9

### 13. Attaching the drip rail

- a) Center the drip rail/top seal in the compartment opening flush against the header. The ends should be even with the outer finishing flange on the track (Fig. 10).

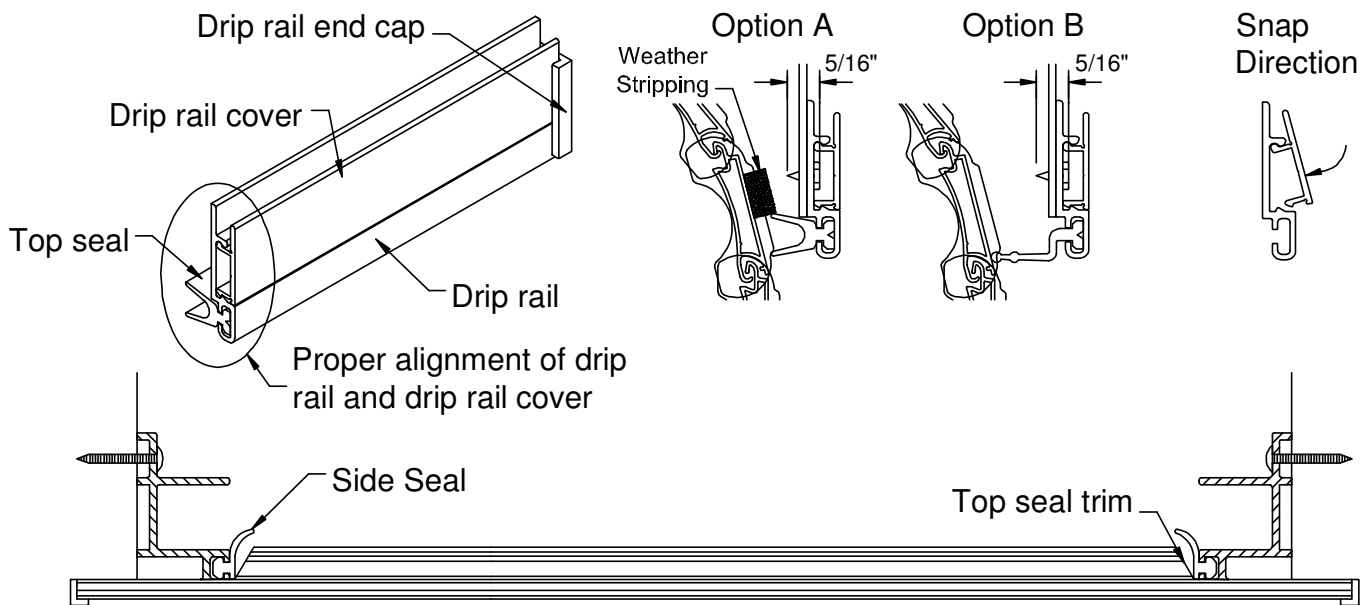
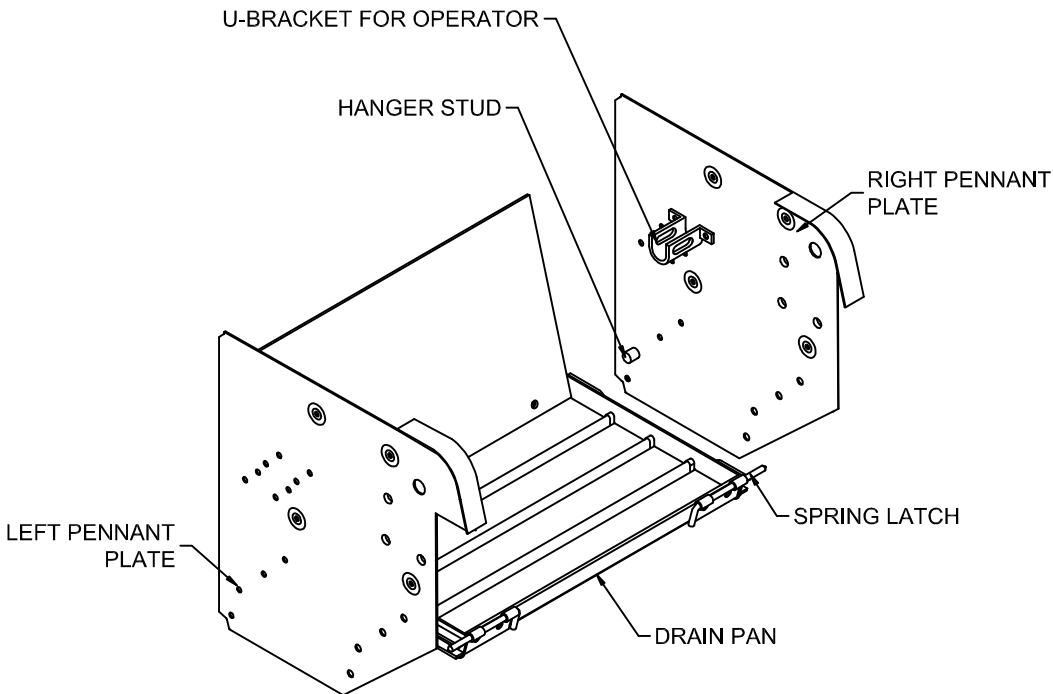

Fig. 10

- b) Remove the excess top seal by cutting the ends to fit between the side seals.
- c) Mount the drip rail to the header using the recommended screws. Be sure that the fasteners do not interfere with the operation of the shutter or cut the foam seal.
- d) Using a soft rubber mallet or protective cloth and metal hammer, tap the snap cover into place or slide the cover into the end of the drip rail. Then using the same equipment tap on both end caps onto either end of the drip rail.

## 14. Installing the Drip Pan (Optional)

- a) Mount pennant plates as shown per Step #4.
- b) To install the drip pan slide the back of the pan onto the hanger studs located at the rear of the pennant plate until the spring latches locate the correct mounting hole to make the pan level.
- c) To clean the pan, retract spring latches and slide off hanger studs to remove.



*Fig. 11*

## 15. Installing the Optional Drain Hose

- a) Install drip pan to verify fit then remove and install optional drain hose.
- b) Drill a 3/8" hole in the drain pan where you would like your drain hose.
- c) Place a small amount of silicone sealant under the flange of the brass insert and push it into the drip pan from the top. With the wire hose clamp installed on the hose about 2" from the end, slide the hose onto the brass insert until flush with the pan. Move the hose clamp up so that the hose can be held in place.

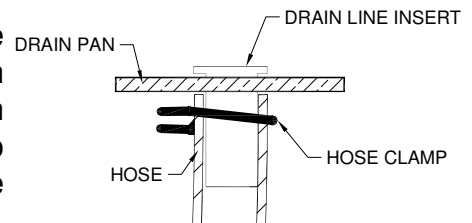

*Fig. 12*

## 16. Control Module Wiring, Door and Lock Test

- a) Finish connecting the electrical connections to the power door control module as shown in the Fig. 14 wiring diagram
- b) The control module is supplied with a sensitivity potentiometer that will adjust the closing force of the door. The potentiometer had 24 turns; clockwise will decrease the sensitivity and counterclockwise will increase it. We recommend fully turning the potentiometer clockwise to decrease the sensitivity and adjusting it to fit your needs after the installation is complete.
- c) After power is applied to the module. Drive the door both directions. If a current meter is available measure the motor current. The normal current range for the motor is .6 to 2.8 Amps. Balance the up/down motor currents by adjusting the operator spring tension see Tension adjustment in the appendix. If a current meter is not available check the spring tension by lowering the lifting the door manually, checking for approximately equal closing and opening forces. Another method of balancing the forces is to time the opening and closing times, and adjusting until the times are approximately the same.

## 17. Manual Override Information

- a) Manual Unlock: Ensure the door can be manually unlocked when locked by the power lock. The power lock can be bypassed during power or lock failure by turning the key to the unlocked position. The key may be turned to the lock position after the door is raised about 1/2". The door will automatically lock when the door is lowered.
- b) Manual Locking the power locks: The power locks maybe manually actuated from the unlocked position to the locked position in case of vehicle power failure. This procedure is should only be completed if the lock pawl is not visible in the track after actuating the lock switch to the "lock" position and the compartment must be immediately locked. Two small holes are located in the power lock component. Insert a small diameter wire (paper clip) about 1/2" into the lower hole. Angle the wire so the end inserted into the lock is further away from the door track. Carefully pry the lock pawl forward until it extends into the track opening. The door will automatically lock on the pawl when the door is lowered and can now be locked and unlocked with the key until power is restored.
- c) Manual door operation: The power door may be raised manually for emergency situations; such as loss of vehicle power or motor/control module problems. Opening the door this way will take additional force caused by the torque motor and gearbox. If the door must be open or closed this way do it **very slowly** as to not damage the motor. Excessive manual operation may damage the motor and void your warranty.

**Note:**

This shutter is virtually maintenance free. Periodically check the shutter for smooth operation. If the door becomes difficult to operate, check the track for proper alignment, tighten fasteners, and clean the door. See the Appendix for more information on maintenance.

**This completes the installation of your Quest 2000 Power Operated Shutter. If you have any questions contact your R-O-M representative at 1-800-827-3692.**

## POWER DOOR CONTROL MODULE WIRING DIAGRAM

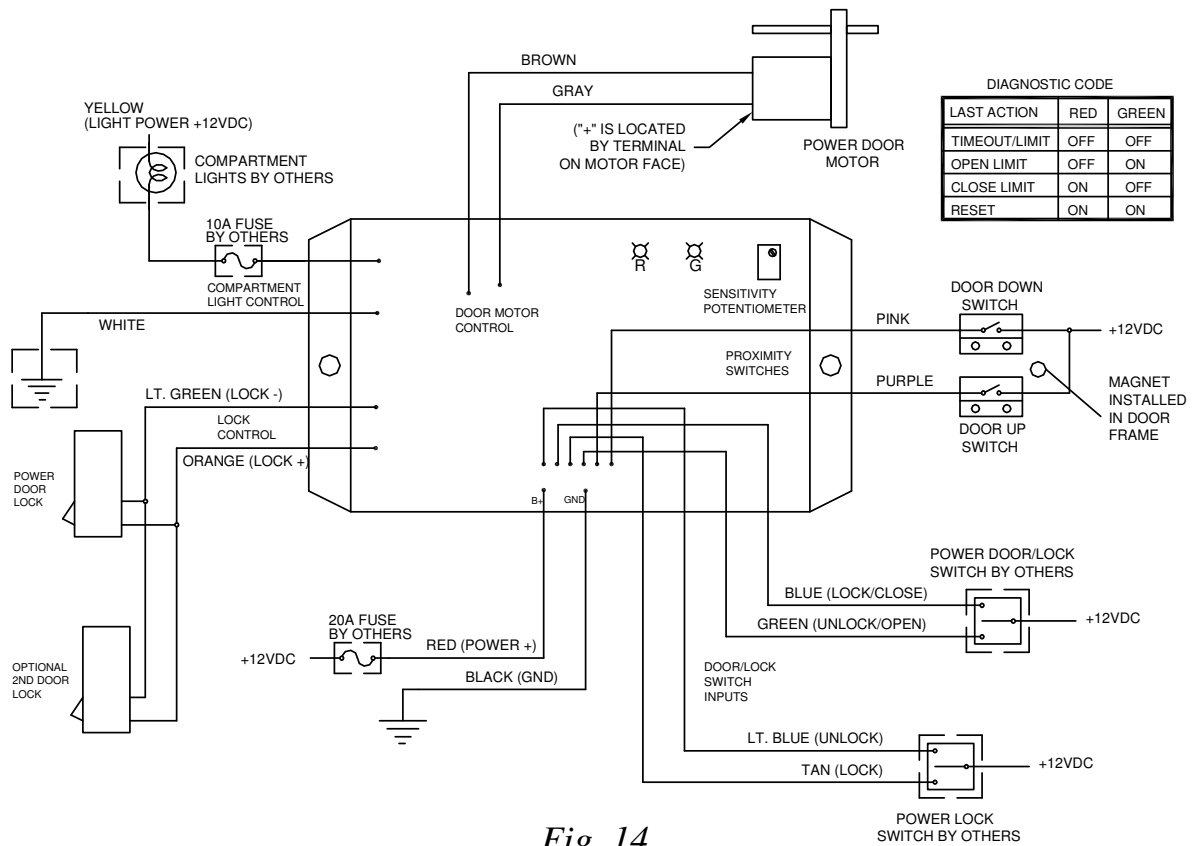
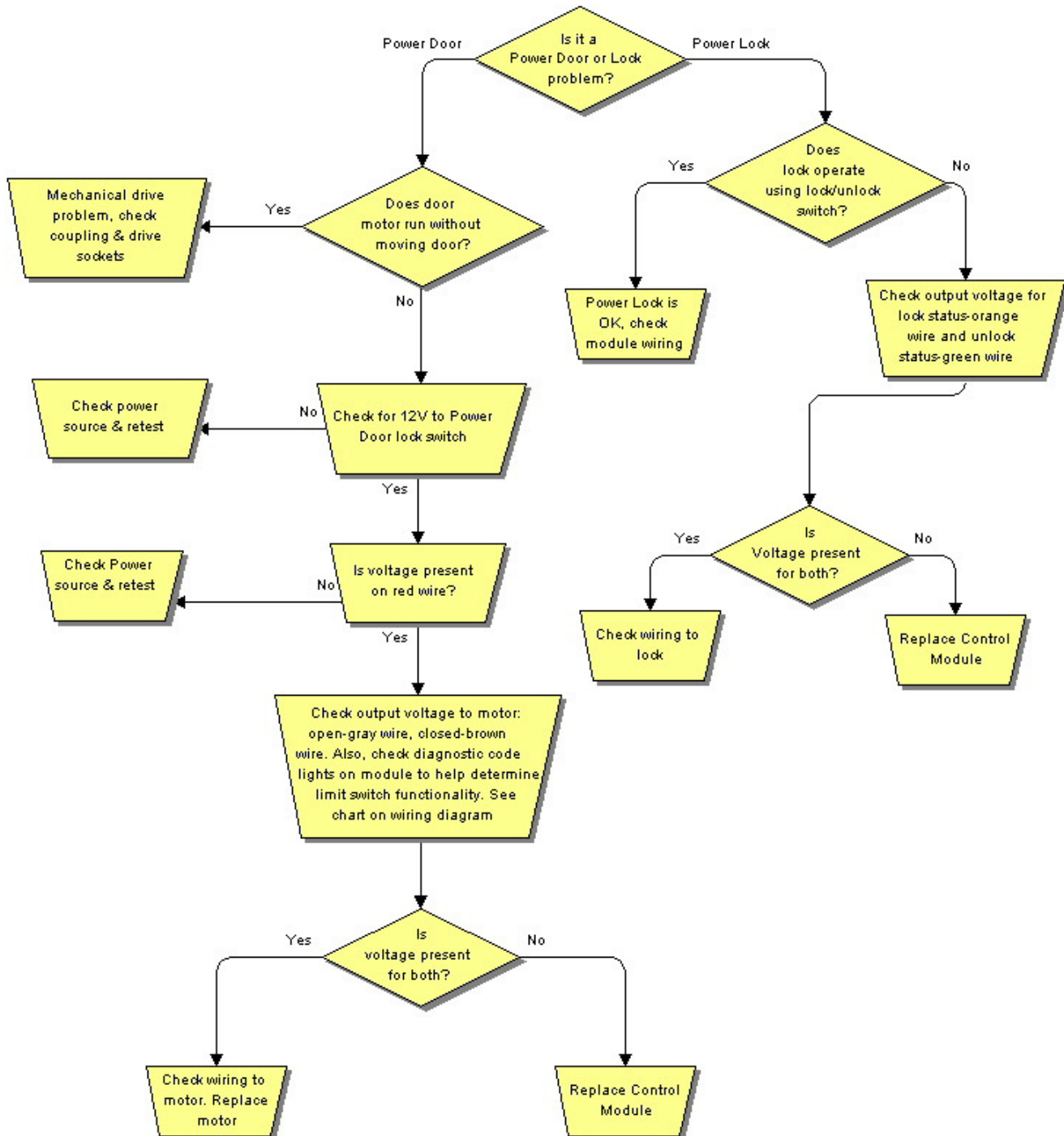

Fig. 14

# Power Door/Power Lock Troubleshooting



# ROM SHUTTER™ SERIES III

Quest 2000 Power Operated System

## ASSEMBLY DRAWING

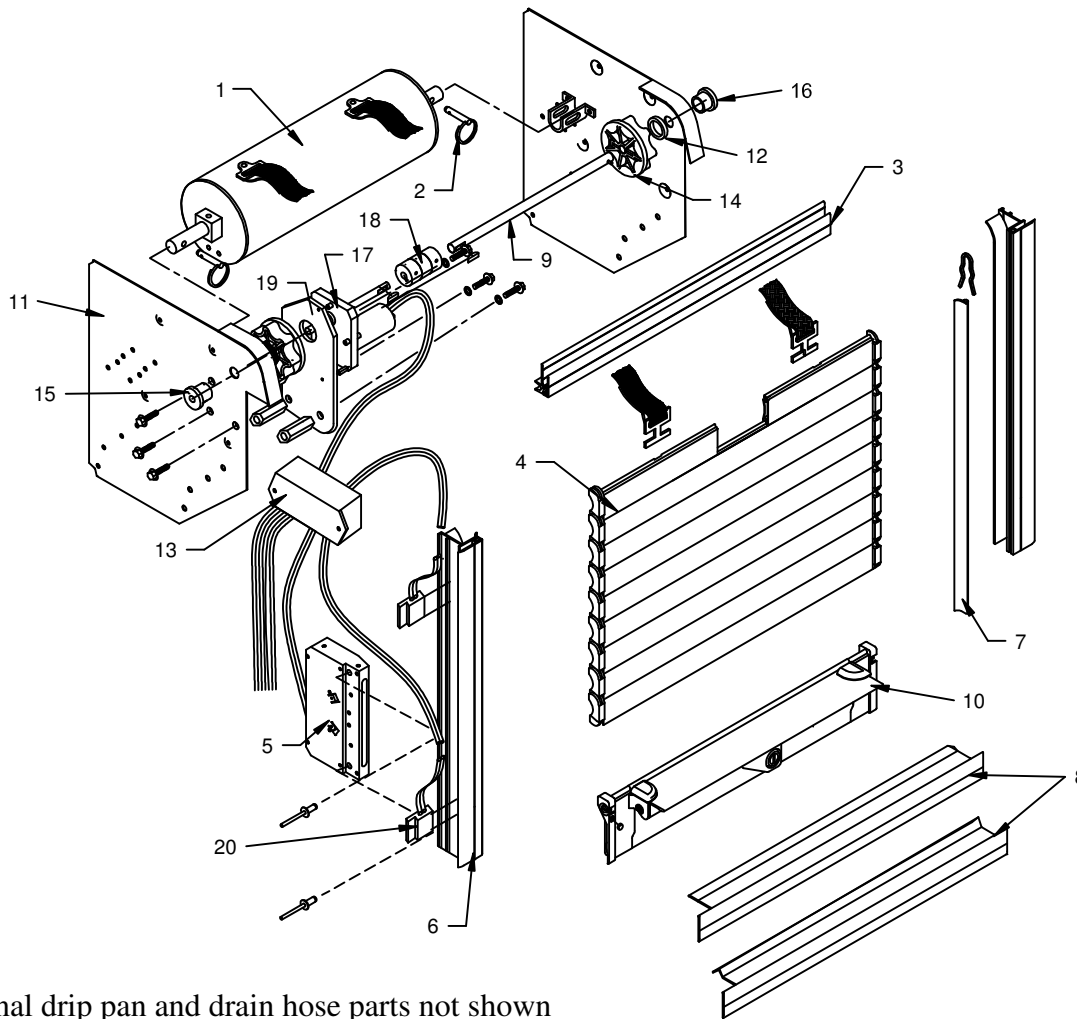

**Note:**

Optional drip pan and drain hose parts not shown

1. Operator	1 ea	11. Pennant Plate	2 ea
2. Detent Ring Pin	2 ea	12. Bearing Washer	2 ea
3. Drip Rail/Top Seal	1 ea	13. Power Door Ctrl Module	1 ea
4. Curtain Assembly	1 ea	14. Drive Sprocket	2 ea
5. Power Lock	Variable	15. Bearing 5/8" OD	1 ea
6. Track	2 ea	16. Bearing 1/2" OD	1 ea
7. Side Seal	1 ea	17. Gear Motor	1 ea
8. Sill Plate (optional)	1 ea	18. 3 Piece Coupling	1 ea
9. Extension Shaft	1 ea	19. Motor Mounting Plate	1 ea
10. Bottom Rail	1 ea	20. Proximity Switch	2 ea

Copyright © 2007 ROM Corporation. All Rights Reserved. These drawings and the information contained herein are the confidential and proprietary intellectual property of ROM Corporation and should not be disclosed to any third party without the express prior written consent of ROM Corporation

# ***APPENDIX***

## **CLEANING, MAINTENANCE, AND TENSION ADJUSTMENT INSTRUCTIONS**

---

### **THE R•O•M SHUTTER IS MADE OF ANODIZED ALUMINUM**

Anodized aluminum is extremely hard and resistant to abrasion. Anodized aluminum can retain its original appearance indefinitely if you follow a sound cleaning and maintenance program. All surfaces are likely to collect dirt and pollutants over time. In some parts of the country, this soiling happens rather quickly due to the level of pollution and proximity to humid coastal regions. With frequent cycles of condensation and drying as experienced in a humid coastal region, salts and pollutants build up very quickly on exterior surfaces. Contamination in recessed areas that are not exposed to the washing effects of rains also builds up more quickly. These soils can become more and more concentrated as they go through cycles of re-wetting and drying. Eventually mild acid pollutants become harsh acid pollutants. These strong acids can attack aluminum causing a pitting type of corrosion. It is important to begin a cleaning maintenance program as soon as you receive your vehicle to prevent soil build-up.

### **I. CLEANING AND MAINTENANCE**

The R•O•M Shutter needs very little maintenance, and cleaning is very simple. To wash the anodized shutter slats, use a mix of water and mild soap or detergent with a PH range between 6 and 9, such as Ivory Liquid, Joy, Lux Liquid, or Dove Liquid. This should be performed without the aid of a high-pressure sprayer.

A 50/50 isopropyl alcohol and water mixture is recommended for cleaning anodized slats prior to applying decals.

If your R•O•M Shutter has been finished with a polyurethane solvent-based paint, then it needs to be cured according to the paint manufacturers recommendation. All solvent-based paints require several weeks to fully cure and harden depending on temperature and humidity. All washing should be performed using a mix of water and mild soap or detergent, without the aid of a high-pressure sprayer.

The tracks should be frequently cleaned to get the best performance and longest life. To clean the track use a mild soap and water to remove any dirt or grime build-up. Spraying the tracks with dry (non-petroleum based) silicone is recommended; this will enhance the smooth opening and closing of the shutter. Do not use any type of petroleum-based lubricant in the tracks, this only attracts dirt and grime and creates an abrasive surface, making it hard to operate the door thus shortening the life of the shutter.

The lift bar should move freely when pulled out and when released should snap back to its rest position.

## CLEANING THE FRICTION AREAS

In the operation of the shutter there are friction areas that will need to be cleaned. After cleaning these points they need sprayed with dry silicone to increase the ease of operation. (**Never use lithium or grease**)

The friction areas on the shutter are as follows:

1. The pennant plates where the end shoes rub against them
2. The roller that the end shoes roll on
3. The nylon end shoes
4. Inside the side track channels
5. The back side of the rubber side seal
6. Outside of the pivot block
7. The drip rail seal at the top of the opening.

(Note: If the drip rail is rubbing against the shutter, the drip rail seal can be trimmed. However, excessive trimming may allow weather and dust to infiltrate the compartment.

## II. TENSION ADJUSTMENT

**The R•O•M Shutter has been factory set so the spring tension of the operator is at equilibrium.** This counterbalance setting will ensure the maximum life expectancy of the shutter and provide consistent operation. Too much tension creates too much force to close the door thus creating more stress on the operator spring, end shoes, and slats. If you feel it is necessary to adjust the operator tension due to a variance in compartment size and actual installation, this can be done easily by following the steps below:

### Before Making any Adjustment to the R•O•M Shutter

1. Make sure all screw heads on the pennant plates and sidetrack channels are not protruding; the nylon end shoes should not touch the screws during operation.
2. Check the compartment to see if it is square. The door will work much easier if the compartment is square. Ideally the shutter should have 1/4" of the total side play when moved laterally at any point. Check the alignment of the pennant plates. They should be parallel and equal distance from the front and bottom of the opening.
3. If the door is difficult to open and close, the shutter may need to be lubricated.
4. If the door opens easily and is difficult to close there may be too much tension. If the door is difficult to open and easy to close, there is not enough tension. If the shutter does not perform to your satisfaction, the tension of the operator may need adjustment.

## A. Adjusting the tension if the compartment is easily accessible

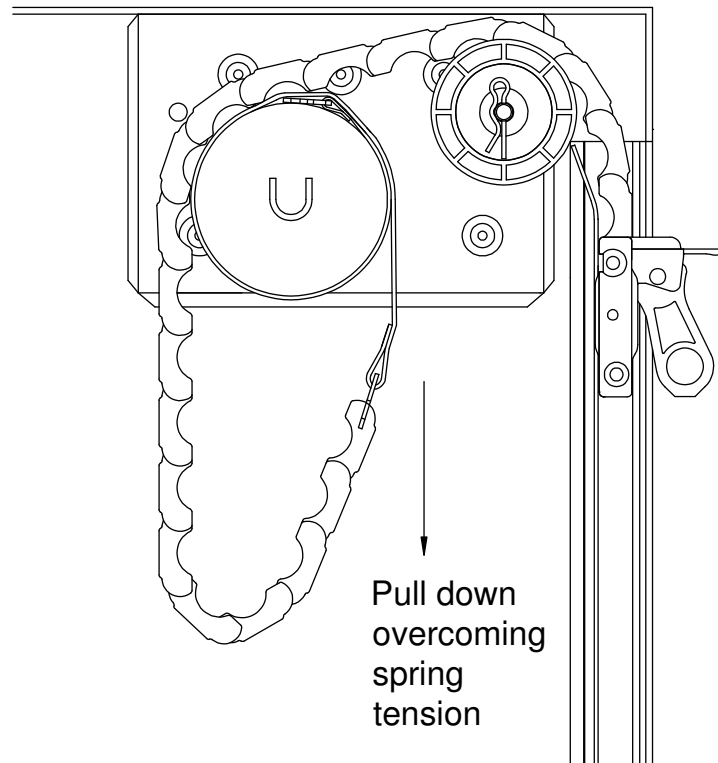

*Ref. Fig. 1*

1. Open the shutter completely.
2. Pull down on the bottom of the roll inside the compartment (Ref. Fig. 1) overcoming spring tension. Pull the curtain of the shutter all the way down so that the operator can be reached.
3. Put the tension pin (nail) back into the hole of the nylon end cap that is located on the right side of the shutter while looking into the compartment. You may need to slightly turn the operator clockwise (towards back of compartment) to align the holes of the end cap with the shaft. The tension pin is always oriented horizontally.
4. Remove the spring retainer pin.
5. Turn operator clockwise one or one-half turn to decrease tension or counterclockwise one or one-half turn to increase tension.
6. Place the spring retainer pin back into the operator.
7. Remove the tension pin and slowly let the tension onto the shutter.

## B. Adjusting the tension from outside the compartment

If you cannot physically access the operator using the method in Section “A”, you must remove the shutter’s track and curtain.

1. Raise the shutter to its open position. Remove all of the fasteners from the track and pull the track out and away from the compartment.
2. Carefully pull the shutter down until the top slat with the strap attachment is sufficiently exposed and the operator can be reached.
3. Put the tension pin back into the hole of the nylon end cap that is located on the right side of the shutter while looking into the compartment. You may need to slightly turn the operator clockwise to align the holes of the end cap with the shaft. The tension pin is always oriented horizontally.
4. Remove the curtain by separating the t-clip strap connection. To separate, lift up on the shutter, rotate clip, and push down and away on the clip.
5. Grip the operator firmly with both hands and have someone remove the locking nail. Turn operator clockwise one or one-half turn to decrease tension or counterclockwise one or one-half turn to increase tension.
6. Replace the tension pin and re-attach the straps to the top slats.
7. Remove the tension pin and slowly let the tension onto the shutter. Route the curtain over the nylon rollers and raise the curtain up to the header. Re-install track.

## III. SLAT REPLACEMENT

If the R•O•M Shutter needs slats replaced, they can be replaced with the slats that are non-visible (Ref. Fig. 2). Do not use the first slats closest to the operator for they have been specifically cut to accommodate the t-clips.

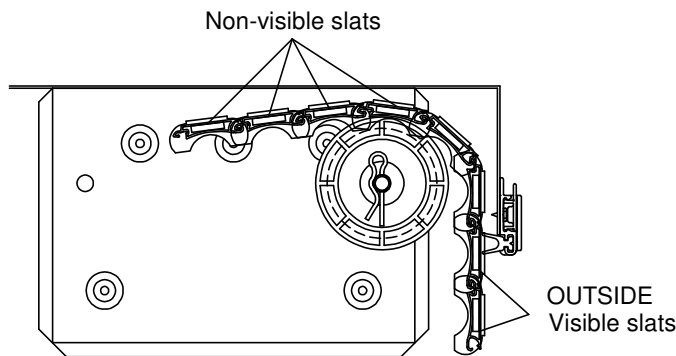

*Ref. Fig. 2*

## **Before you begin**

This procedure requires that you lay the curtain and track on its face. Always remember to protect the face of the curtain and any other visible parts.

1. To remove the drip rail assembly, refer to step 13 to see how it was installed.
2. To remove the track assembly, refer to step 11 to see how the track was installed. Remember to remove the sealant used to seal the track. This will insure that the new sealant will adhere correctly during the track reinstallation.
3. To detach the curtain assembly, refer the step 8 to see how the curtain was attached. Once the curtain assembly has been detached you will need to lay it on its face using a blanket, rug, towel, or any other kind of soft material that will prevent the curtain from being scratched.
4. To remove the end shoes, grasp the middle of the end shoe with a vise grip and twist out until the end shoes slides out of the end of the slat. (See Ref. Fig 3.)

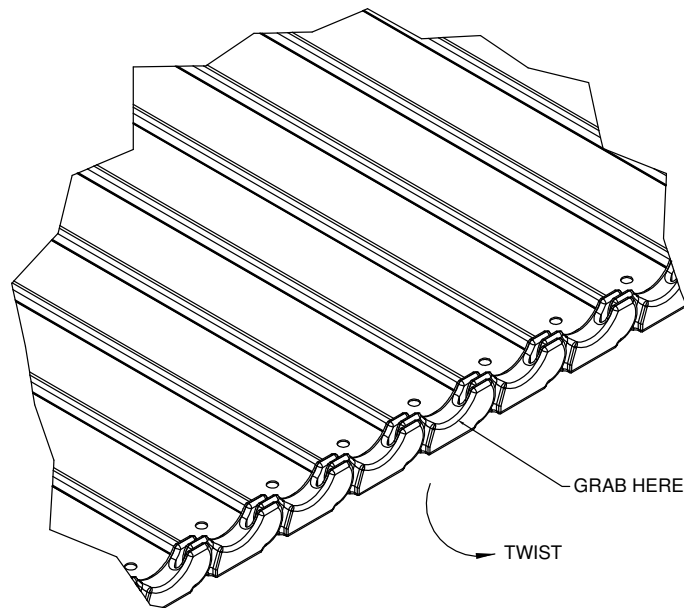

*Ref. Fig. 3*

5. After removing the end shoes on both sides slide out the damaged slat and the hidden slat. Replace the damaged slat with the hidden slat and reassemble.
6. Place one end of the curtain against a back stop. Then, install the end shoes on the opposite side by tapping the end shoes with a small hammer. The end shoes should be tapped in until flush and look like they did prior to taking them off. Rotate the curtain around and repeat.
7. After the slats and end shoes have been replaced, re-install the shutter following steps 8, 11, and 13 of the installation instructions.