



Excellence made to order.



6800 East 163rd Street
Belton, MO 64012-5463
816-318-8000
1-800-827-3692
FAX 816-318-8100

R•O•M SHUTTER™ SERIES III

INSTALLATION INSTRUCTIONS

FM-7.5-234
Rev F
8/26/10

Congratulations on your purchase of the R•O•M Roll-Up Shutter!

Please read and carefully follow these instructions!

You will need the following parts and tools for installing your Shutter; please note that these are not included with your system.

- Fasteners for drip rail and track (Self-tapping hex-head #10 machine or sheet metal screws are recommended)
- Drill
- Drill bits-#29, 11/64" 3/16", 3/8", and 1/2"
- Clear indoor/outdoor silicone sealant
- Screwdriver – Phillips
- Wire cutters
- Wire crimp
- Tape measure
- Marking pen
- Pop rivet gun for 3/16" pop rivets
- Rubber headed mallet
- Pliers/Vise Grips
- Wire nuts and/or solder less connector for joining 20 gauge wires to vehicle wiring if power locks are required
- Single Pole Double Throw Momentary Switches for Lock Input Switches (On)-Off-(On) if power locks are required

Overview

For a successful installation of the R•O•M shutter, follow these steps:

- 1) Unpacking
- 2) Pre-Drilling Holes
- 3) Attaching the Sill Plate
- 4) Attaching the Pennant Plates
- 5) Hanging the Operator
- 6) Hanging the Curtain
- 7) Attaching the Striker Blocks
- 8) LED Lighting
- 9) Installing the power lock
- 10) Attaching the Track
- 11) Attaching the Drip Rail
- 12) Installing the drip pan
- 13) Installing the pull rope
- 14) Testing the Door Operation

1. Unpacking

- a) Unpack and carefully lay out all of the parts. The shutter if unrolled should be placed on a smooth, clean, soft surface to prevent scratching the finish on the slats.
- b) Make sure all parts shown on the assembly drawing on page 13 are included.

2. Pre-Drilling Holes

If your process involves pre-drilling all the holes in body prior to the finishing operation, follow these steps. If you do not pre-drill the holes, they must be drilled as you install the components.

Pre-drilling using templates

- a) If pre-drilling with templates, drill holes for track, pennant plates, and drip rail at this time.

Pre-drilling using door parts

- a) Looking into the compartment, place the pennant plate right hand pennant plate label in the top right of the compartment as shown in Fig. 1. Make sure it is flush with the top of the compartment and 1-5/8" from the vehicle skin. Reference instruction #12 if optional drip pan is ordered.
- b) Match drill four 11/64" holes for each pennant plate. **Note:** Rear roll design requires additional holes.

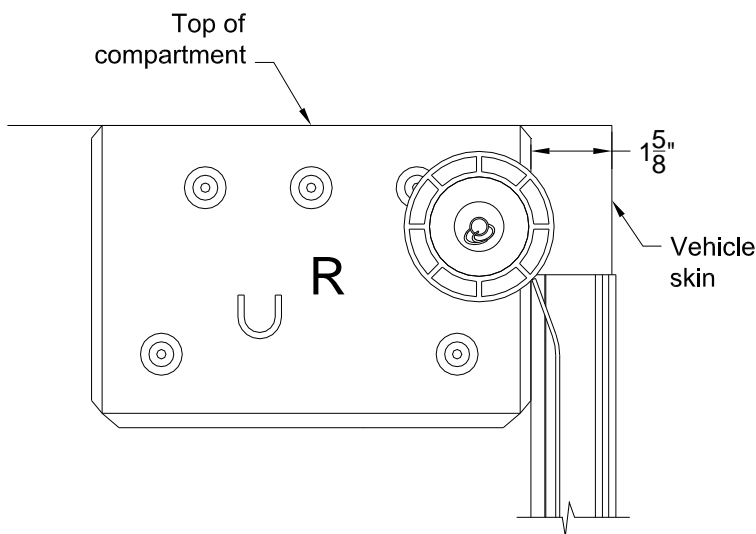

Fig. 1

- c) Position the track between the header and the bottom of the compartment. Make sure the bottom of the track touches the bottom of the compartment. (Fig 2.) The finishing flange should be flush against the skin of the vehicle. Optional track configurations are shown in Fig. 2a.

Note: If the sill plate option is included, place the track on the sill plate or 1/8" up from the bottom of the compartment prior to drilling.

d) If pre-drilled track was ordered. Match drill 11/64" holes in the vehicle body where slots are present in the track.

e) If the manual locking option is included, match drill 3/8" holes in the side of the vehicle for the locking rod, using the pre-drilled hole in the track as a guide.

f) Center the base section of the drip rail/top seal in the compartment opening flush against the header. The ends should be even with the outer finishing flange on the track.

g) Drill holes in the drip rail where necessary for attachment. The maximum fastener length should be 5/16" long. A hex head fastener is recommended for easy removal of the drip rail. Use the centering groove on the drip rail when installing the screws.

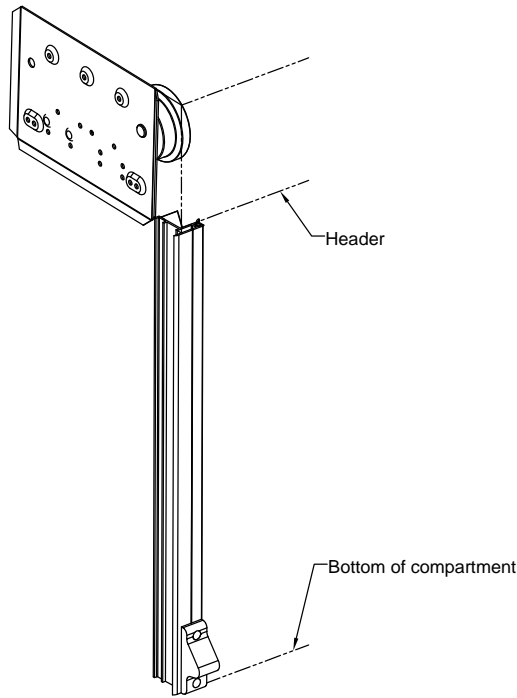

Fig. 2

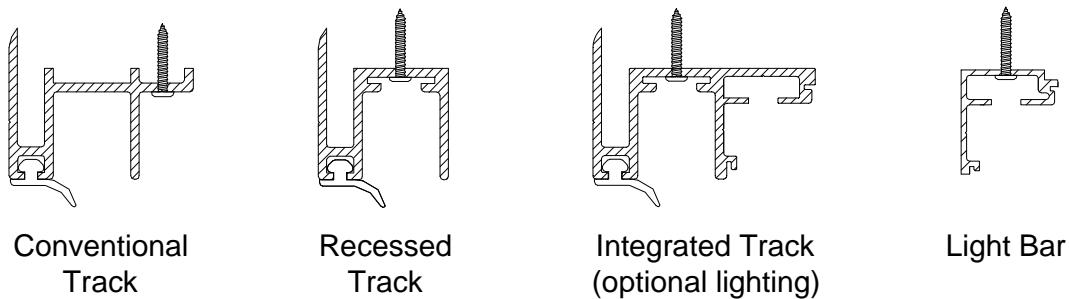

Fig. 2a

Do not attach drip rail until step 9!

3. Attaching the Sill Plate (optional)

a) Place the sill plate in the center of the bottom compartment. The notches should be on the top as shown in Fig. 3.

b) Make sure the bottom of the compartment is clean, then remove the backing from the tape on the sill plate and attach.

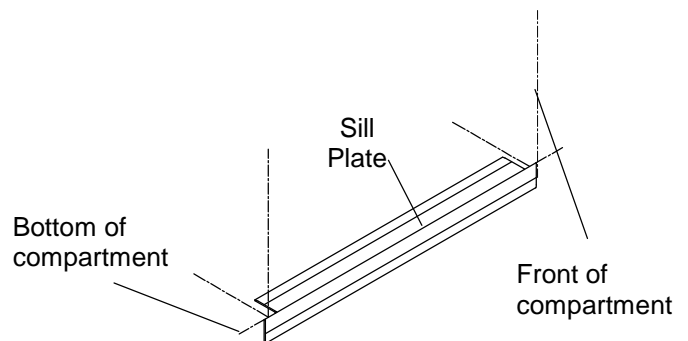

Fig. 3

4. Attaching the Pennant Plates

- a) Mount the pennant plates. Making sure the operator is level in the compartment.
- b) Reference instruction #12 if optional drip pan is ordered.

5. Hanging the Operator

- a) Place the operator shaft into the u-brackets on the pennant plates. The label will be on the right while looking into the compartment as shown in Fig. 4

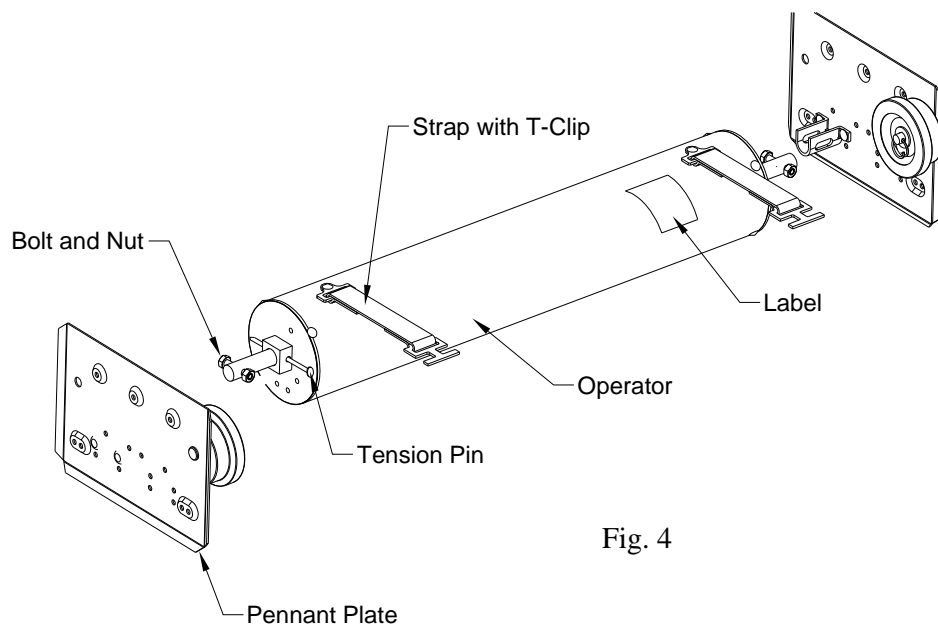

Fig. 4

- b) Let the straps hang as shown in Fig. 5. Straps should wrap around the operator diameter approximately $1\frac{1}{4}$ times, then drape down approximately 5".

- c) Insert spring retainer pin on both u-brackets.

6. Hanging the Curtain

- a) Feed the top slat of the shutter over the nylon rollers and operator as shown in Fig. 5. Let the curtain hang behind the operator. Gravity should hold the curtain in this position the bottom rail against the header.
- b) With the curtain in the position shown, place the T-Clip into the slots on the top slats and secure.
- c) Slightly rotate the operator clockwise and remove the tension pin (nail). Reverse the rotation and slowly roll shutter completely open, so the bumpers on the bottom rail touch the header.

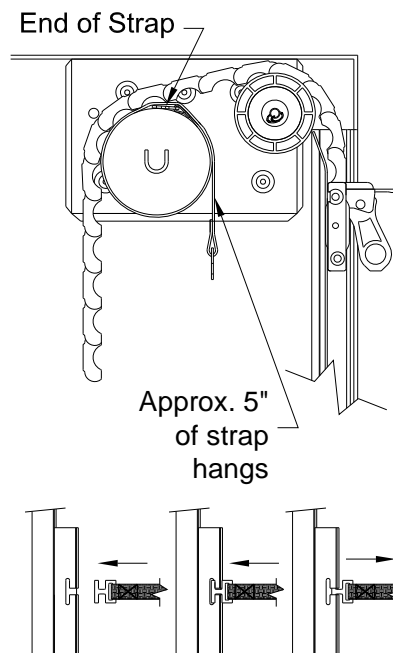

Fig. 5

7. Attaching the Striker Blocks

If holes were not pre-drilled, mount the bottom of the striker block flush with the track for standard bottom rail (Fig. 7), $\frac{1}{2}$ " from the bottom for bottom rail extension (Fig. 7a) and $1\frac{1}{2}$ " from the bottom for tall bottom rail (Fig. 7b). Match drill two $\frac{3}{16}$ " holes, then using the rivets provided pop rivet the striker block to the track. If a door ajar switch system is required drill a $\frac{1}{2}$ " hole for feeding the wire through located $\frac{17}{32}$ " below the top mounting hole. All holes should be free of burrs.

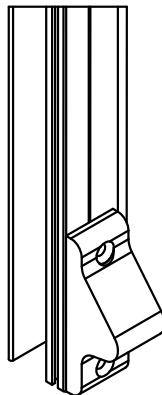

Fig. 7

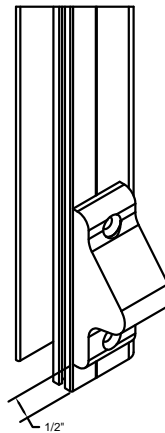

Fig. 7a

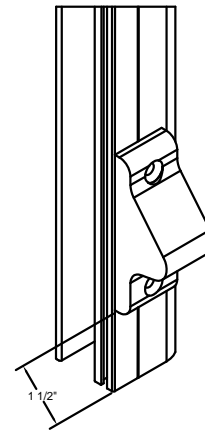

Fig. 7b

Without Door Ajar Switch System (D.A.S.S.)

- a) Pop rivet the striker blocks to the track.

With Door Ajar Switch System (D.A.S.S.)

- a) Install the switch on the appropriate side of track; feed the wires through the middle hole by sliding the 3-inch length of sleeve toward the free ends of the wires, leaving the sleeve on the wires. Insert the 3-inch sleeve half way through the D shaped hole. While holding the sleeve in that position, pull the wires through it to prevent scaring the wire insulation. After the switch is installed, slide the sleeve to the location where the wires exit the track. It is suggested that a "repair loop" of wire be retained in the track by forming the wires into a compressed "Z" shape. The switch wiring can exit the wire relief on the top or the bottom of the track (see additional instructions when running thru the door frame). Note: clay rope or tape can be installed to help hold the wire in the track during installation.

Running the wiring thru the door frame:

- ◇ Drill $\frac{1}{2}$ " hole in door frame to route the wires through at the same height as the wires on the track, the hole should be free of burrs. Then, place the track into position making sure the protective sleeve is positioned to protect the wires when pulling thru.
- b) Pop rivet the second striker block or second door ajar switch on the opposite track.
- c) Go to step 8 if compartment lighting has been ordered. Then, wire the switch using the wiring diagrams provided in Fig. 8.
- d) Turn on the power and check the system for proper function.

(Preferred Wiring)

Lights to Ground Thru Solid State
Switch Configuration

Indicator Lights to +12-24 VDC 8 Amps Max
(Supply voltage of less than 11V can
cause switch to malfunction)

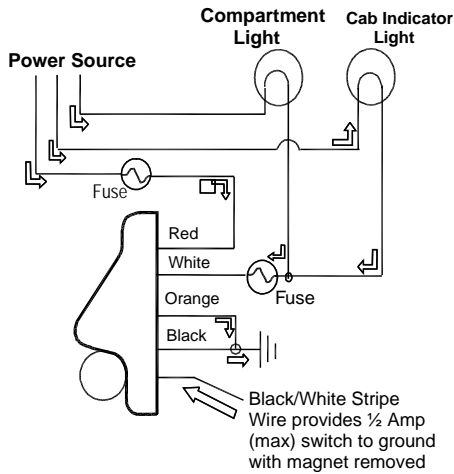

Lights to Power Thru Solid State
Switch Configuration
Indicator Lights to Ground
(Supply voltage of less than 9V can
cause switch to malfunction)

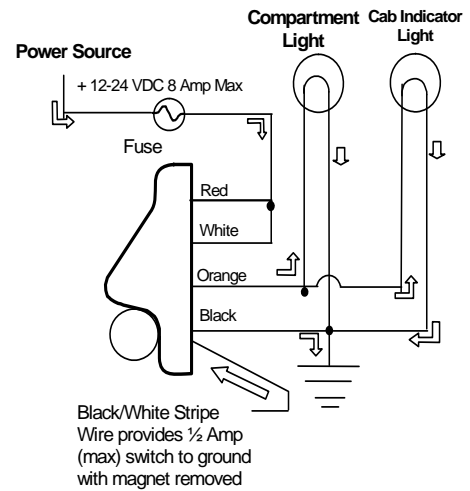

Fig.8

Wiring Test Procedure:

This device has a solid-state output switch, and polarity is important. Damage to the device may result from extended operation with improper connection of the wires.

To determine if proper installation has been achieved, check the operation of the door ajar switch by applying a magnet (R•O•M Part # R00011 or any strong magnet) to the door ajar switch where the lift bar rests when the door is closed. When the door is open the compartment light should be illuminated. Therefore, when the magnet makes contact with the door ajar switch the light should turn off. If the compartment light remains on when the magnet makes contact with the door ajar switch, reverse the white and orange wire connections, and repeat the above procedure. If proper operation is still not achieved, re-check the wiring connections for proper wiring.

Optional Output

The new switch design has a single output that can be split to provide power to both compartment lights and a door ajar indicator light in the cab of the vehicle. If you have multiple indicator lights in the cab that show which door is open, the new design will work with no additional components or modifications. This can be performed using the black wire with white strip wired directly to the light; unless the current draw is more than a 1/2 amp then it will be necessary to use this wire to provide a controlled ground for an optional relay or electronic control provided by user.

8. LED Lighting (optional)

NOTE: Reference FM-7.5-231 for LED V2 and FM-7.5-255 for LED V3 Lighting Installation Instructions.

9. Installing the Power Lock (Optional)

- a) Mount the power lock to the track if not factory installed. The track will be pre-drilled and slotted for the power lock. Mount the lock with 3/16" pop rivets (Fig. 16) Recessed track will have mounting brackets for the power lock to be mounted to.
- b) Ensure the lock pawl moves freely after mounting.
- c) Mount the control module so that it is out of the way, mounting it just behind the track is recommended. Route the power lock wires to the power door control module using care to protect the wires. Connect the light green and orange wire from the power lock to the light green and orange wire on the power door control module. If two locks are used connect all wires together. See wiring diagram below.

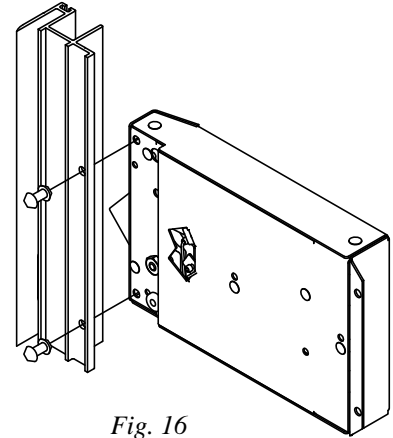
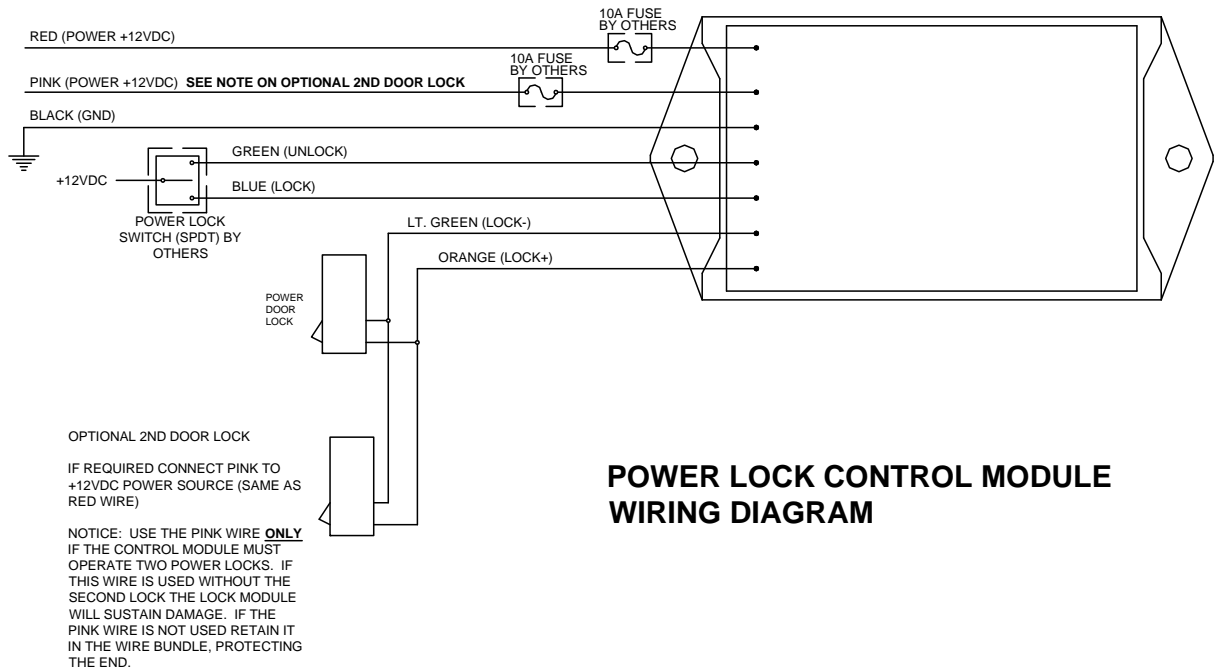

Fig. 16



Manual Override information:

- a) **Manual Unlock:** Ensure the door can be manually unlocked when locked by the power lock. The power lock can be bypassed during power or lock failure by turning the key to the unlocked position. The key may be turned to the lock position after the door is raised about $\frac{1}{2}$ ". The door will automatically lock when the door is lowered.
- b) **Manually locking the power locks:** The power locks maybe manually actuated from the unlocked position to the locked position in case of vehicle power failure. This procedure should only be completed if the lock pawl is not visible in the track after actuating the lock switch to the "lock" position and the compartment must be immediately locked. Two small holes are located in the power lock component. Insert a small straight screwdriver about 1" into the lower hole. Angle the screwdriver so the end inserted into the lock is further away from the door track. Carefully pry the lock pawl forward until it extends into the track opening. The door will automatically lock on the pawl when the door is lowered and can now be locked and unlocked with the key until power is restored.

10. Attaching the Track

- a) While tilting the bottom rail outward slide the track on it.

Notice: If the door ajar wires are not correctly tucked into the track, the wires can be easily damaged. See step 7 for additional wire routing information.

- b) Rotate the track toward the vehicle body, and attach with the recommended fasteners.

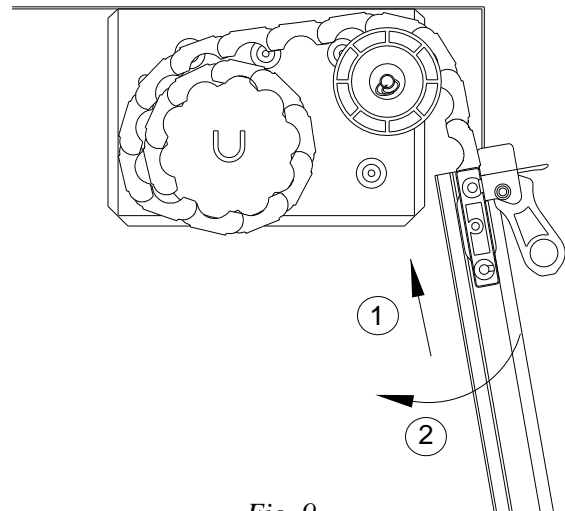

Fig. 9

- c) To create a watertight opening, use a silicone sealant to seal between the track, sill plate (optional), and compartment. Silicone sealant can also be applied under the striker block or DASS and around the bottom of the track if it does not seat properly with the bottom of the compartment opening.
- d) The side seal nearest the sill plate should be trimmed so that it is flush with the sill plate. Be careful not to cut the seal too short, this will allow water to enter at this location.
- e) Shipped loose with your shutter was a label with lubrication instructions. Please place it so that the end user can see it when the compartment is full of equipment.

11. Attaching the Drip Rail (optional)

- a) Center the drip rail/top seal in the compartment opening flush against the header. The ends should be even with the outer finishing flange on the track.

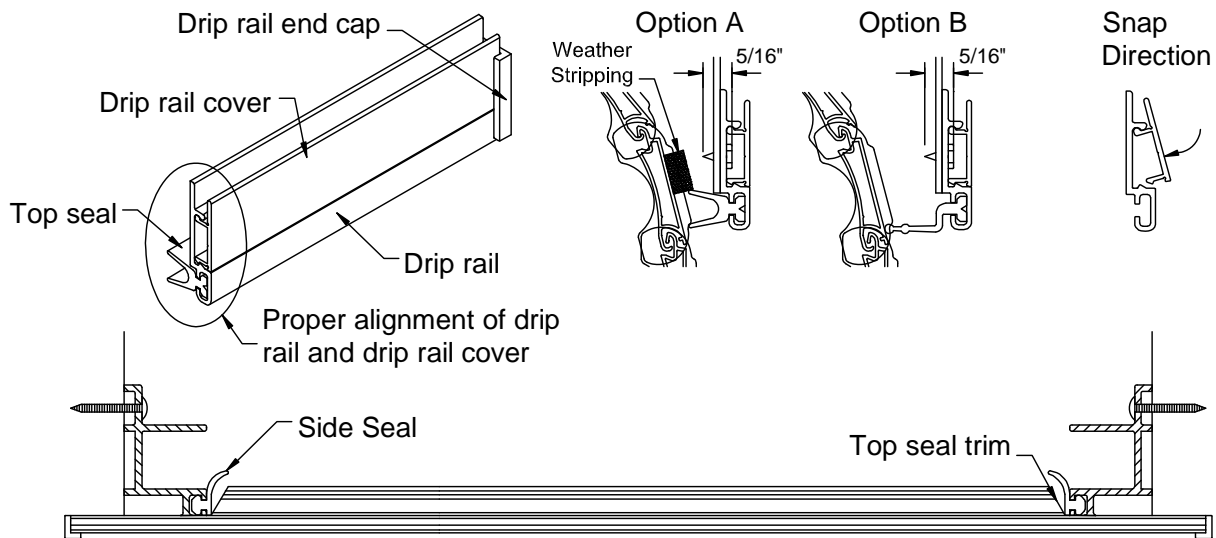

Fig. 12

- b) Remove the excess top seal by cutting the ends to fit between the side seals.
- c) Mount the drip rail to the header using the recommended screws previously discussed. Be sure that the fasteners do not interfere with the operation of the shutter or cut the weather stripping.
- d) Using a soft rubber mallet or protective cloth and metal hammer, tap the snap cover into place. Then using the same equipment tap on both end caps onto the ends of the drip rail.

12. Installing the Drip Pan (optional)

- a) Mount drip rail pennant plates as shown per instruction #4. First, determine what size pennant plate you have by referencing the label on the back of the plate. If the pennant plate is an A, B, or C; place the drip pan pennant plate flush up against the existing pennant plate as shown in Fig. 1. Making sure the hanger stud is placed on the same side of the U-Bracket as shown. For D size pennant plates the top of the drip pan plates will need to be mounted 3" below the pennant plate.
- b) To clean the pan, retract spring latches and slide off hanger studs to remove.

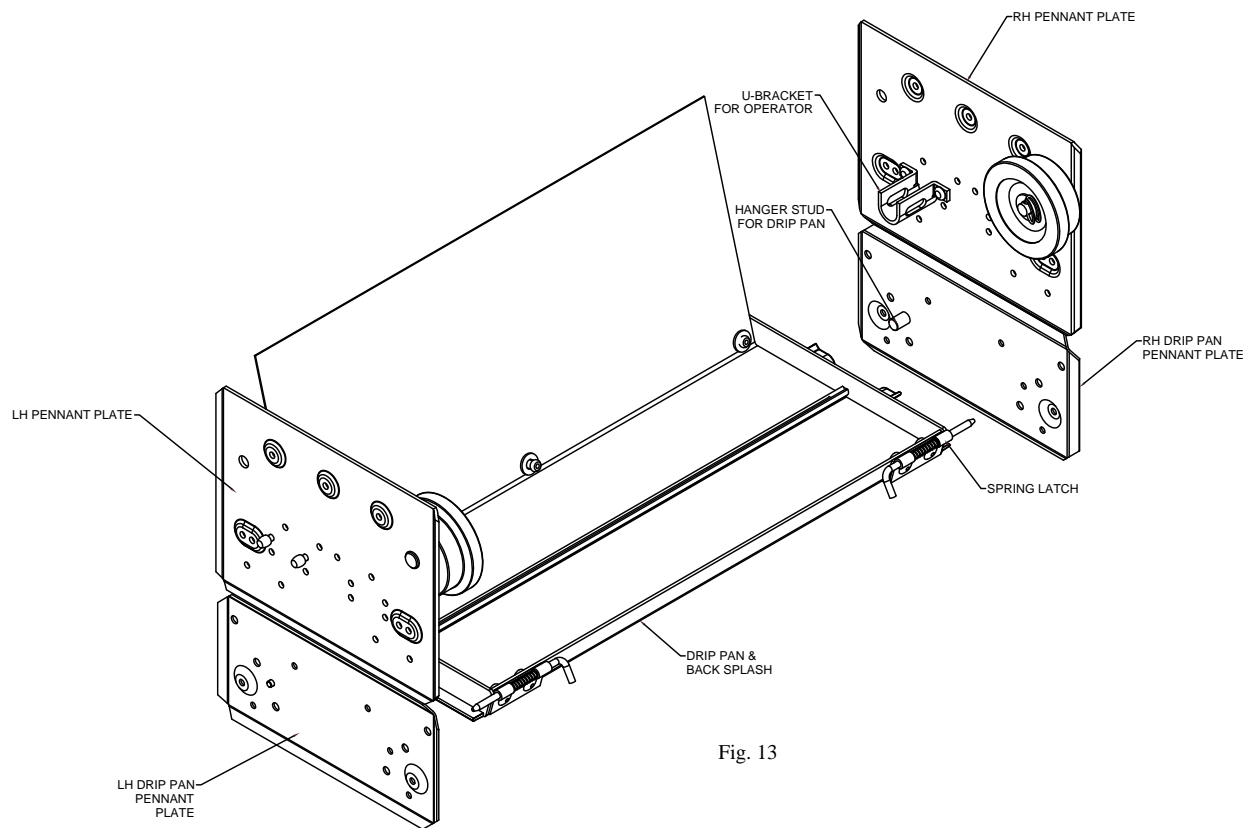

Fig. 13

To Install the Drain Hose (Optional):

- a) Install drip pan to verify fit then remove and install optional drain hose.
- b) Drill a 3/8" hole in the drip pan where you would like your drain hose.
- c) Place a small amount of silicone sealant under the flange of the brass insert and push it into the drip pan from the top. With the wire hose clamp installed on the hose about 2" from the end, slide the hose onto the brass insert until flush with the pan. Move the hose clamp up so that the hose can be held in place.

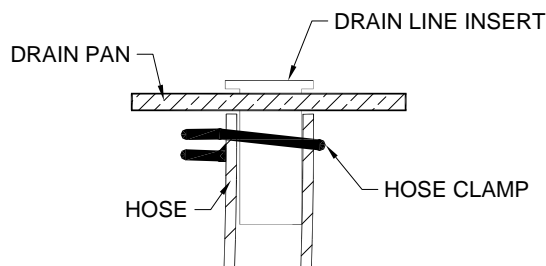

Fig. 14

13. Installing the pull rope (optional)

For pull rope installation: Secure the loop end of the pull rope using a Monobolt or sheet metal screw and washer (provided by others) at the opening height of the compartment under the pennant plate as shown in the adjacent figure. The loop connector on the fastening end can be adjusted if needed for alternate placement if required.

To adjust the pull rope grip: Loosen both screws so that it moves up or down the rope to the desired location, then re-tighten the screws.

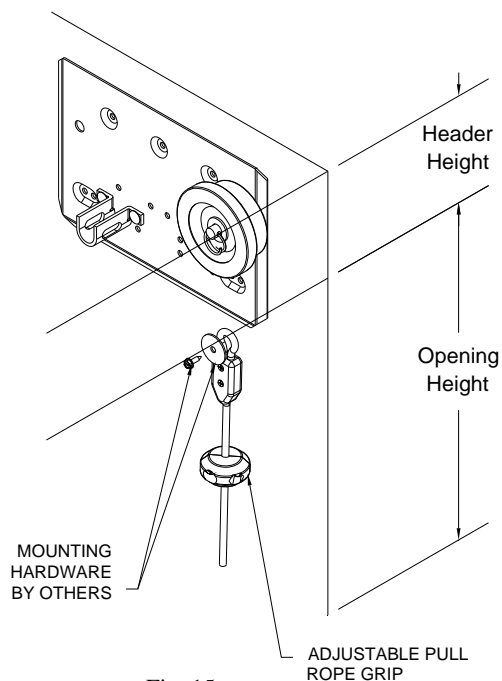

Fig. 15

14. Testing Door Operation

Open the shutter by pulling the lift bar out past the striker blocks and up. When closing the shutter, use the finger pull at the top of the bottom rail, rather than the lift bar. If the door is tight or takes too much force to open and close, see **Cleaning and Maintenance** and **Tension Adjustment** in the Appendix.

Note:

This shutter is virtually maintenance free. Periodically check the shutter for smooth operation. If the door becomes difficult to operate, check the track for proper alignment, tighten fasteners, and clean the track. See the Appendix for more information on maintenance.

Do not use oil or grease of any kind on this product. If lubrication is required, a dry silicone spray (non-petroleum based) is recommended.

If you have any questions, please call R•O•M Corporation at 1-800-827-3692.

Copyright © 2009 R•O•M Corporation. All Rights Reserved. These drawings and the information contained herein are the confidential and proprietary intellectual property of R•O•M Corporation and should not be disclosed to any third party without the express prior written consent of R•O•M Corporation.

Power Lock Diagnostic Information Power Locks Only

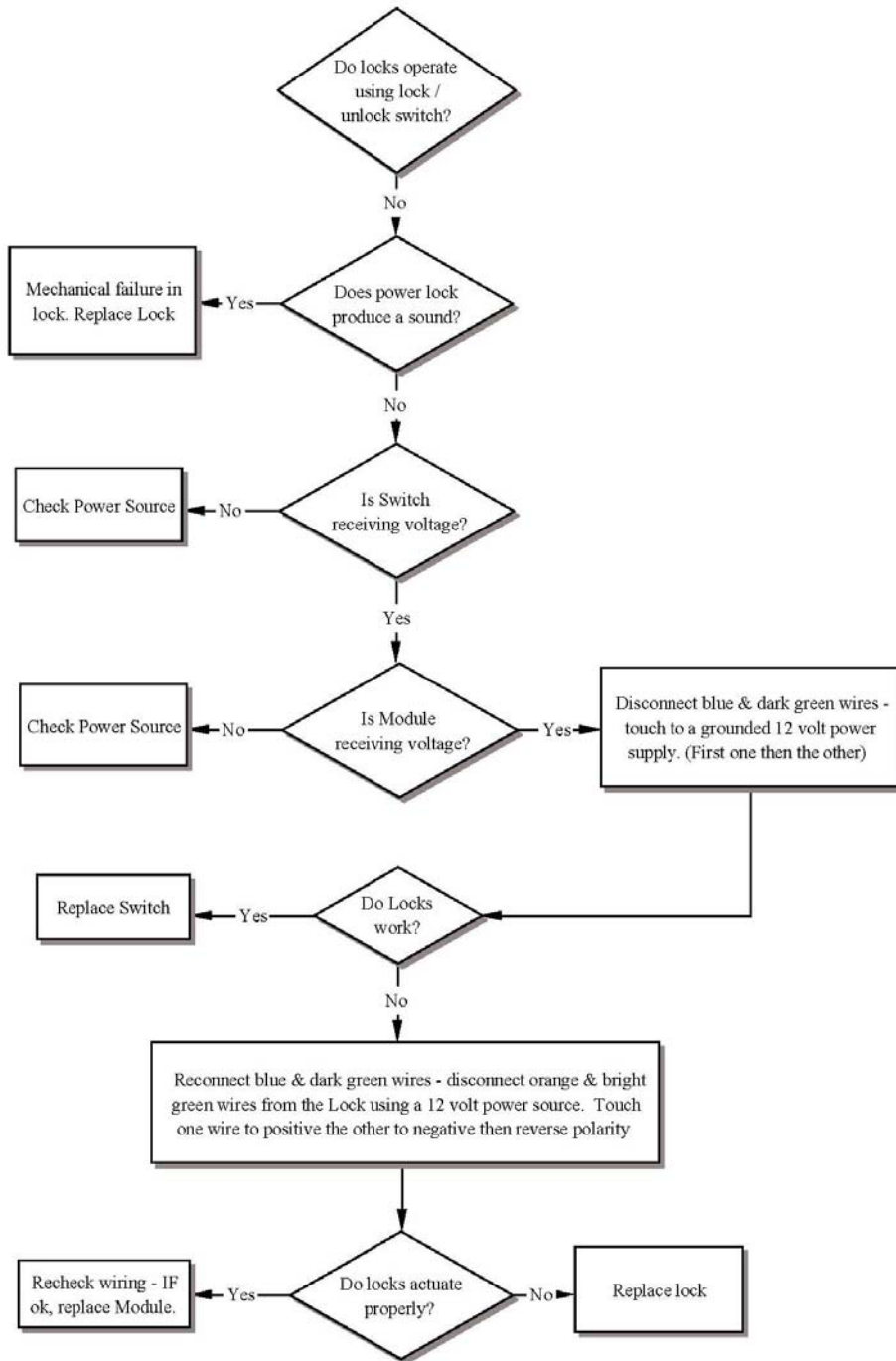

R·O·M SHUTTER™ SERIES III Assembly Drawing

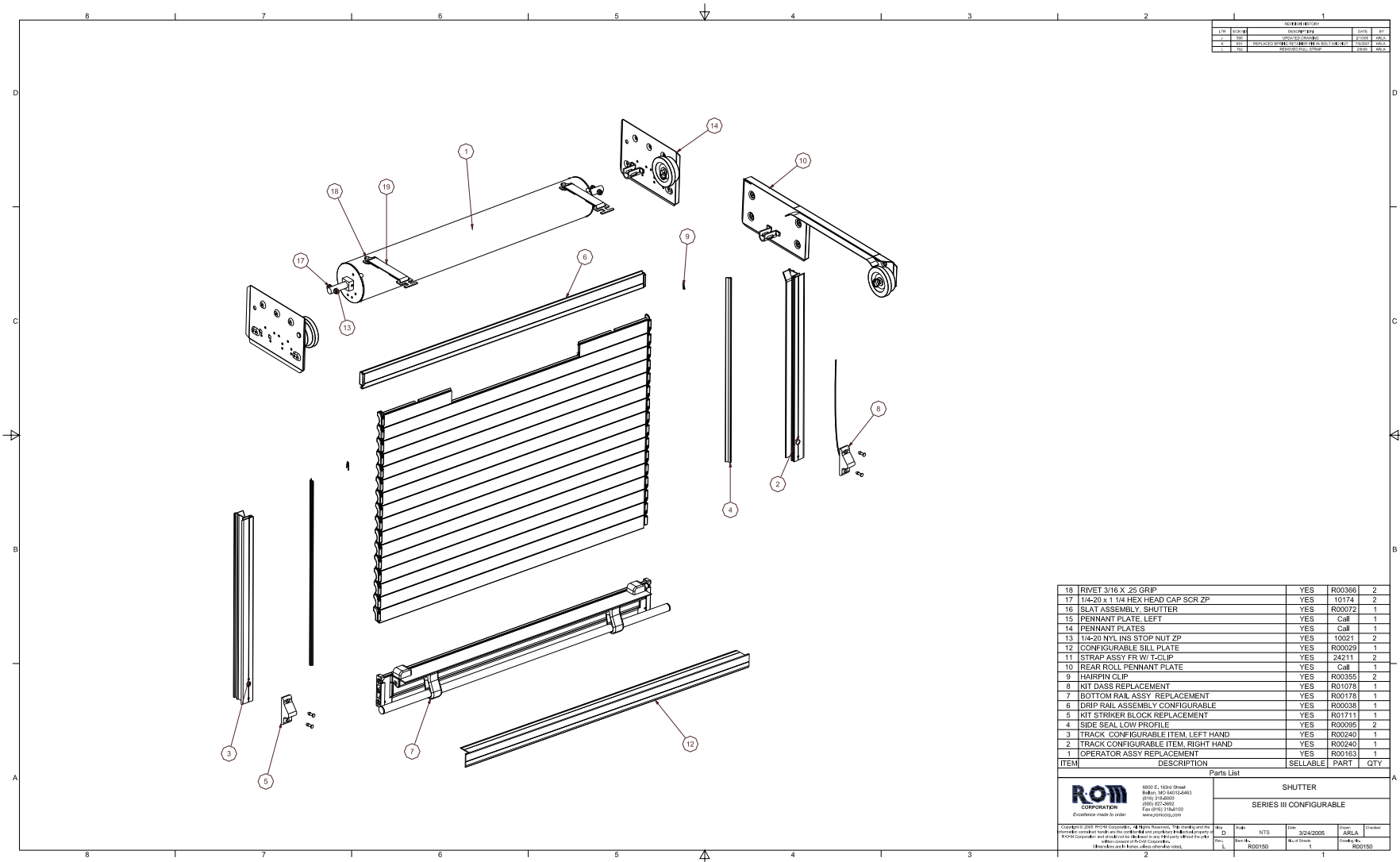

REV	DATE	DESCRIPTION	BY	CHK
1	02/24/2005	ISSUED FOR PRODUCTION	JD	JD
2	02/24/2005	ISSUED FOR PRODUCTION	JD	JD
3	02/24/2005	ISSUED FOR PRODUCTION	JD	JD

ITEM	DESCRIPTION	SELLABLE	PART	QTY
18	RIVET 3/16 X .25 GRIP	YES	R00366	2
17	1/4-20 x 1 1/4 HEX HEAD CAP SCR ZP	YES	10174	2
16	SLAT ASSEMBLY SHUTTER	YES	R00072	1
15	PENNANT PLATE, LEFT	YES	Call	1
14	PENNANT PLATES	YES	Call	1
13	1/4-20 NYL INS STOP NUT ZP	YES	10021	2
12	CONFIGURABLE SILL PLATE	YES	R00029	1
11	STRAP ASSY FR W/ T-CLIP	YES	24211	2
10	REAR ROLL PENNANT PLATE	YES	Call	1
9	HAIRPIN CLIP	YES	R00355	2
8	KIT DASS REPLACEMENT	YES	R01078	1
7	BOTTOM RAIL ASSY REPLACEMENT	YES	R00178	1
6	DRIP RAIL ASSEMBLY CONFIGURABLE	YES	R00038	1
5	KIT STRIKER BLOCK REPLACEMENT	YES	R01711	1
4	SIDE SEAL LOW PROFILE	YES	R00095	2
3	TRACK CONFIGURABLE ITEM, LEFT HAND	YES	R00240	1
2	TRACK CONFIGURABLE ITEM, RIGHT HAND	YES	R00240	1
1	OPERATOR ASSY REPLACEMENT	YES	R00183	1

Parts List		SHUTTER	
		SERIES III CONFIGURABLE	
REV	NTS	DATE	02/24/2005
REV	R00190	REV	1
REV	R00190	REV	R00190



8000 E. 16th Street
 Denver, CO 80232-6483
 (303) 750-0000
 (800) 825-8892
 Fax: (303) 750-0000
 www.romcorp.com

Copyright © 2005 ROM Corporation. All Rights Reserved. The ROM logo and the ROM Corporation name are trademarks of ROM Corporation. All other trademarks are the property of their respective owners.

APPENDIX

CLEANING, MAINTENANCE, AND TENSION ADJUSTMENT INSTRUCTIONS

THE R•O•M SHUTTER IS MADE OF ANODIZED ALUMINUM

Anodized aluminum is extremely hard and resistant to abrasion. Anodized aluminum can retain its original appearance indefinitely if you follow a sound cleaning and maintenance program. All surfaces are likely to collect dirt and pollutants over time. In some parts of the country, this soiling happens rather quickly due to the level of pollution and proximity to humid coastal regions. With frequent cycles of condensation and drying as experienced in a humid coastal region, salts and pollutants build up very quickly on exterior surfaces. Contamination in recessed areas that are not exposed to the washing effects of rains also builds up more quickly. These soils can become more and more concentrated as they go through cycles of re-wetting and drying. Eventually mild acid pollutants become harsh acid pollutants. These strong acids can attack aluminum causing a pitting type of corrosion. It is important to begin a cleaning maintenance program as soon as you receive your vehicle to prevent soil build-up.

I. CLEANING AND MAINTENANCE

The R•O•M Shutter needs very little maintenance, and cleaning is very simple. To wash the anodized shutter slats, use a mix of water and mild soap or detergent with a PH range between 6 and 9, such as Ivory Liquid, Joy, Lux Liquid, or Dove Liquid. This should be performed without the aid of a high-pressure sprayer.

A 50/50 isopropyl alcohol and water mixture is recommended for cleaning anodized slats prior to applying decals.

If your R•O•M Shutter has been finished with a polyurethane solvent-based paint, then it needs to be cured according to the paint manufacturers recommendation. All solvent-based paints require several weeks to fully cure and harden depending on temperature and humidity. All washing should be performed using a mix of water and mild soap or detergent, without the aid of a high-pressure sprayer.

The tracks should be frequently cleaned to get the best performance and longest life. To clean the track use a mild soap and water to remove any dirt or grime build-up. Spraying the tracks with dry (non-petroleum based) silicone is recommended; this will enhance the smooth opening and closing of the shutter. Do not use any type of petroleum-based lubricant in the tracks, this only attracts dirt and grime and creates an abrasive surface, making it hard to operate the door thus shortening the life of the shutter.

The lift bar should move freely when pulled out and when released should snap back to its rest position.

CLEANING THE FRICTION AREAS

In the operation of the shutter there are friction areas that will need to be cleaned. After cleaning these points they need sprayed with dry silicone to increase the ease of operation. (**Never use lithium or grease**)

The friction areas on the shutter are as follows:

1. The pennant plates where the end shoes rub against them
2. The roller that the end shoes roll on
3. The nylon end shoes
4. Inside the side track channels
5. The back side of the rubber side seal
6. Outside of the pivot block
7. The drip rail seal at the top of the opening.

(Note: If the drip rail is rubbing against the shutter, the drip rail seal can be trimmed. However, excessive trimming may allow weather and dust to infiltrate the compartment.

II. TENSION ADJUSTMENT

The R•O•M Roll-up Shutter Door has been factory set so the spring tension of the operator is at equilibrium; meaning approximately the same force is required to open or close. This counterbalance setting will ensure the maximum life expectancy of the roll-up door and provide consistent operation. Too much tension creates too much force to close the door thus creating more stress on the operator spring, end shoes, and slats. If you feel it is necessary to adjust the operator tension due to a variance in compartment size and actual installation, this can be done easily by following the steps below:

Please read the following before making any adjustment to the R•O•M Roll-up Door

1. Make sure all screw heads on the pennant plates and sidetrack channels are not protruding; the nylon end shoes should not touch the screws during operation.
2. Check the compartment to see if it is square. The door will work much easier if the compartment is square. Ideally the roll-up door should have $\frac{1}{4}$ " of the total side play when moved laterally at any point. Check the alignment of the pennant plates. They should be parallel and equal distance from the front and bottom of the opening.
3. If the door is difficult to open and close, the roll-up door may need to be lubricated.
4. If the door opens easily and is difficult to close there may be too much tension. If the door is difficult to open and easy to close and/or the curtain drapes loosely around the operator drum, there is not enough tension. If the roll-up door does not perform to your satisfaction, the tension of the operator may need adjustment.

Note: The factory number of turns is identified on a label located on the right side of operator drum.

A. Adjusting the tension if the compartment is easily accessible

1. Open the roll-up door completely.
2. Pull down on the bottom of the roll inside the compartment (Ref. Fig. 1) overcoming spring tension. Pull the curtain of the roll-up door all the way down so that the operator can be reached.
3. Put the tension pin (nail) back into the hole of the nylon end cap that is located on the right side of the roll-up door while looking into the compartment. You may need to slightly turn the operator clockwise (towards back of compartment) to align the holes of the end cap with the shaft. The tension pin is always oriented horizontally.

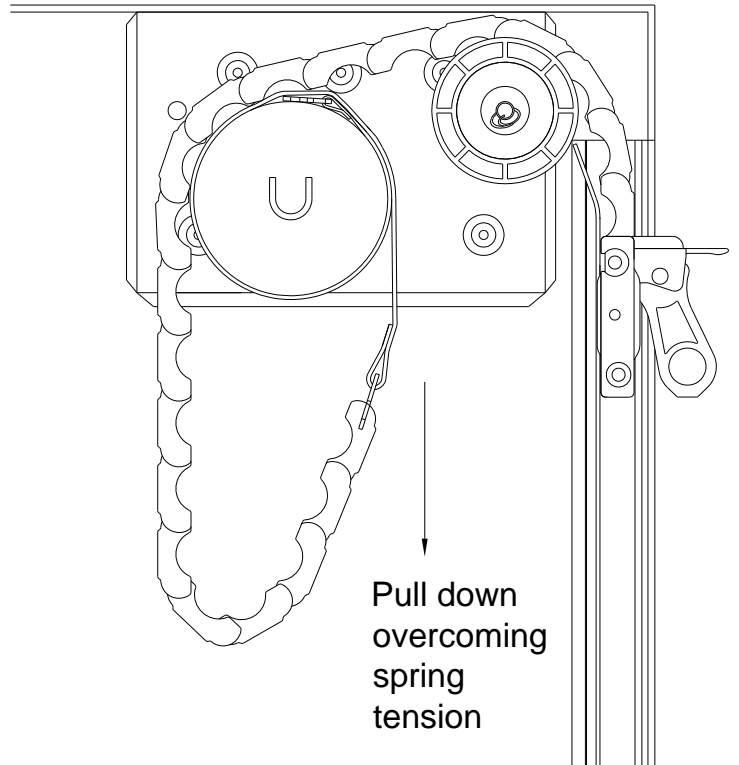

Ref. Fig. 1

4. Remove the operator securement fasteners (Hex Head Cap Screw; ¼-20 x 1 1/4" & ¼-20 nut) at each end of the operator shaft.
5. Turn operator clockwise one or one-half turn to decrease tension or counterclockwise one or one-half turn to increase tension.
6. Replace the operator securement fasteners at each end of operator shaft.
7. Remove the tension pin and slowly allow tension to be transferred back onto the roll-up door curtain.

Adjusting the tension from outside the compartment

If you cannot physically access the operator using the method in Section “A”, you must remove the roll-up door’s track and curtain.

1. Raise the roll-up door to its open position. Remove all of the fasteners from the track and pull the track out and away from the compartment.
2. Carefully pull the roll-up door down until the top slat with the strap attachment is sufficiently exposed and the operator can be reached.
3. Put the tension pin back into the hole of the nylon end cap that is located on the right side of the roll-up door while looking into the compartment. You may need to slightly turn the operator clockwise to align the holes of the end cap with the shaft. The tension pin is always oriented horizontally.
4. Remove the curtain by separating the t-clip strap connection. To separate, lift up on the roll-up door, rotate clip, and push down and away on the clip.
5. Grip the operator firmly with both hands and have someone remove the locking nail. Turn operator clockwise one or one-half turn to decrease tension or counterclockwise one or one-half turn to increase tension.
6. Replace the tension pin and re-attach the straps to the top slats.
7. Remove the tension pin and slowly allow tension to be transferred back onto the roll-up door curtain. Route the curtain over the nylon rollers and raise the curtain up to the header. Re-install track.

III. SLAT REPLACEMENT

If the R•O•M Shutter needs slats replaced, they can be replaced with the slats that are non-visible (Ref. Fig. 2). Do not use the first slats closest to the operator for they have been specifically cut to accommodate the t-clips.

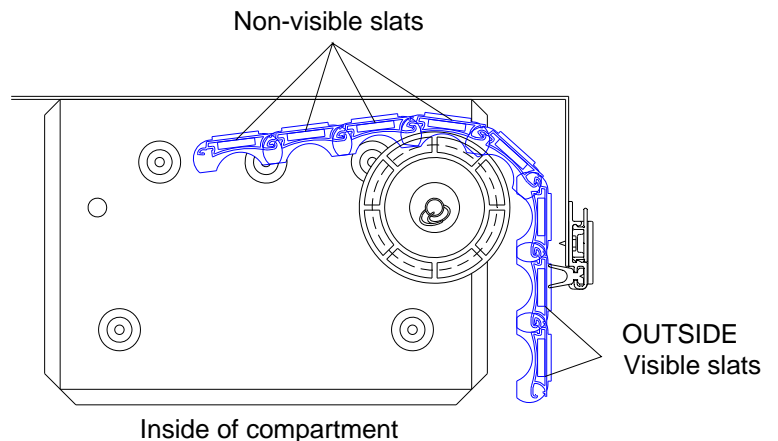

Ref. Fig. 2

Before you begin

This procedure requires that you lay the curtain and track on its face. Always remember to protect the face of the curtain and any other visible parts.

1. To remove the drip rail assembly, refer to step 11 to see how it was installed.
2. To remove the track assembly, refer to step 9 to see how the track was installed. Remember to remove the sealant used to seal the track. This will insure that the new sealant will adhere correctly during the track reinstallation.
3. To detach the curtain assembly, refer the step 6 to see how the curtain was attached. Once the curtain assembly has been detached you will need to lay it on its face using a blanket, rug, towel, or any other kind of soft material that will prevent the curtain from being scratched.
4. To remove the end shoes, grasp the middle of the end shoe with a vise grip and twist out until the end shoes slides out of the end of the slat. (See Ref. Fig 3.)
5. After removing the end shoes on both sides slide out the damaged slat and the hidden slat. Replace the damaged slat with the hidden slat and reassemble.
6. Place one end of the curtain against a back stop. Then, install the end shoes on the opposite side by tapping the end shoes with a small hammer. The end shoes should be tapped in until flush and look like they did prior to taking them off. Rotate the curtain around and repeat.
7. After the slats and end shoes have been replaced, re-install the shutter following steps 6, 9, and 11 of the installation instructions.

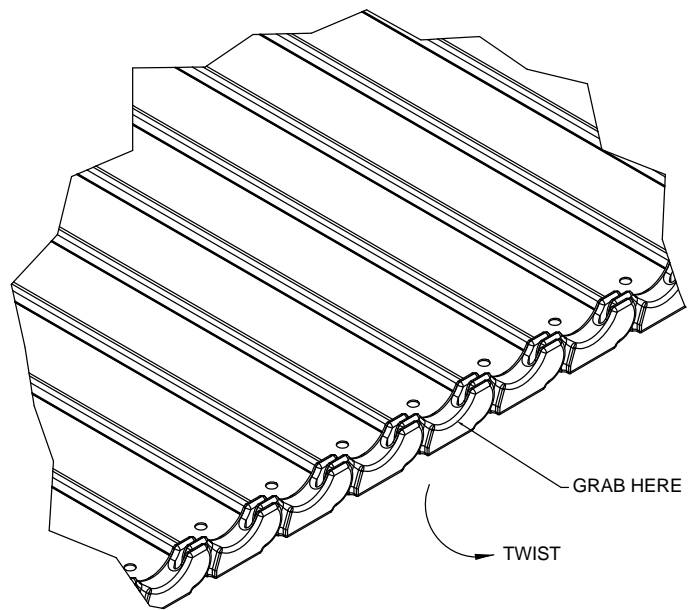

Ref. Fig. 3