

# Roll-Up Door Data and Drawings

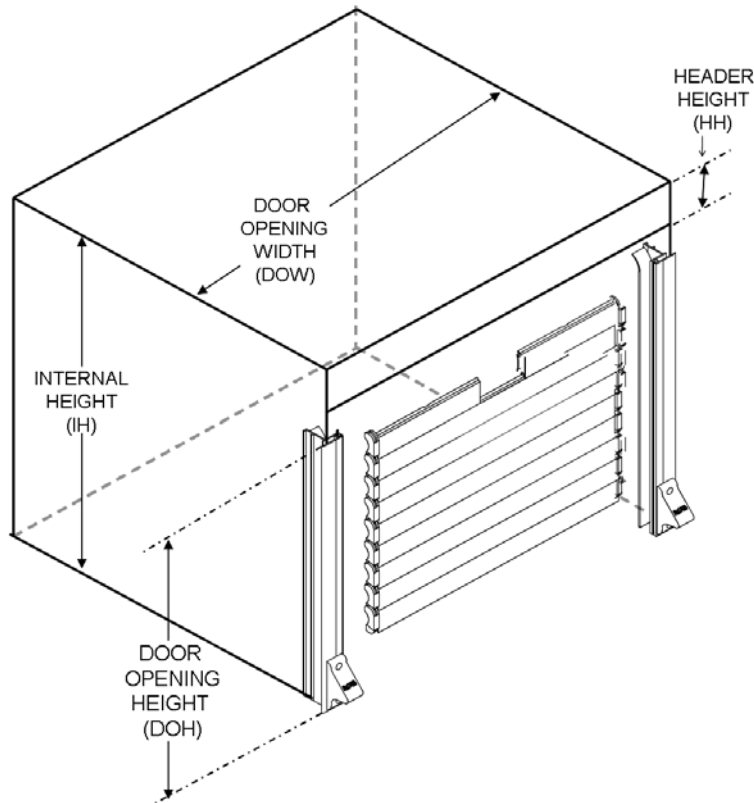

## Sizes

- Width range: 15"–90"
- Internal height range: 17"–104"
- Available in any combination in between.

## Options

- Manual security key lock
- Patented power door lock with manual override
- Remote keyless entry
- Patented automatic power door system
- Patented door ajar switch
- Sill plate
- Tall bottom rail
- Bottom rail extension
- Pull rope for tall doors
- Brushed finish or Perfect Match Wet Paint
- Drip pan
- Custom track profiles: recessed, interior, integrated lighting

## Standard Features

- Heavy duty finger pull
- Satin-finish slats
- Full-width lift bar handle
- Pre-drilled track and pre-installed striker blocks as requested
- Choice of available track styles
- Pre-set counterbalance

## Slat Finishes

- *Satin (standard):* A smooth anodized finish.
- *Brushed (optional):* Keeps with the look of other brushed finishes on the vehicle.
- *Perfect Match Wet Paint (optional):* Complements your vehicle by using the same paint for the roll-up doors that is used on the truck.

**R.O.M.**  
CORPORATION

Excellence made to order.

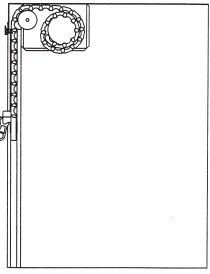

Front Roll Door Side View

### Front Roll Door Description

- Most commonly specified door type.
- Operator is located at the front of the compartment to meet your equipment requirements.
- Counterbalanced for easy opening and closing.
- Easy to install and maintain.
- Made of individual aluminum slats, allowing quick repairs with little downtime.
- End shoes are swaged/dimpled into the slat, not riveted, to allow easy slat replacement.

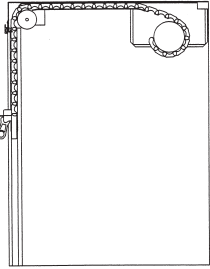

Rear Roll Door Side View

### Rear Roll Door Description

- Same features and options as front roll doors.
- When equipment requirements don't allow a front roll, the operator is mounted toward the rear to better meet your needs.
- Rear-mounted counterbalance maximizes compartment opening space.
- Rear roll doors provide greatest benefits when compartment is more than 24" deep.

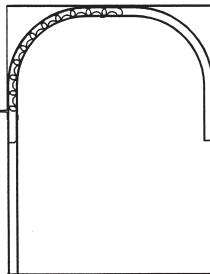

AutoLatch Side View

### AutoLatch Shutters for Interior Compartments

- AutoLatch rolls in a track across the top and down the back of the compartment.
- Ideal for small compartments where space is at a premium.
- Easy to operate and virtually no maintenance.
- The door stops raising or lowering as soon as you stop applying pressure.
- Nylon innerseal between slats ensures quiet, vibration-free performance.
- Interlocking nylon end shoes connecting the slats allow smooth operation.
- Optional lock provides added security.

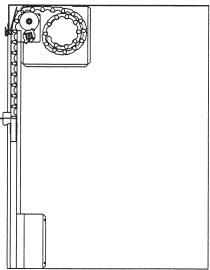

Power Door Side View

### Quest 2000 Patented Power Doors and Locks

- A push of a button – from the cab or other strategic location on the vehicle – raises the vehicle's roll-up doors.
- As soon as the vehicle stops and the brakes are set, the doors are open. That saves time, so personnel can focus on fighting fires and saving lives.
- The same switch can be activated to lower the doors and lock them securely.

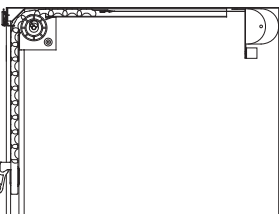

MHS Door Side View

### Minimum Header Shutter (MHS) Door Description

- MHS shutter rolls in a track across the top of the compartment.
- Ideal for compartments where header space is required to be at a minimum, such as ladder compartments.
- Rear-mounted stainless steel tape counterbalance, which replaces the front operator, helps to maximize the compartment's clear opening space and minimize the header space requirements.
- Easy to install and maintain.



Excellence made to order.



6800 E. 163rd St.  
Belton, MO 64012  
800-827-3692  
[www.romcorp.com](http://www.romcorp.com)  
[sales@romcorp.com](mailto:sales@romcorp.com)

Copyright © 2008 R•O•M Corporation. All rights reserved.