

LINKSGUARD

2000 SERIES INSTALLATION

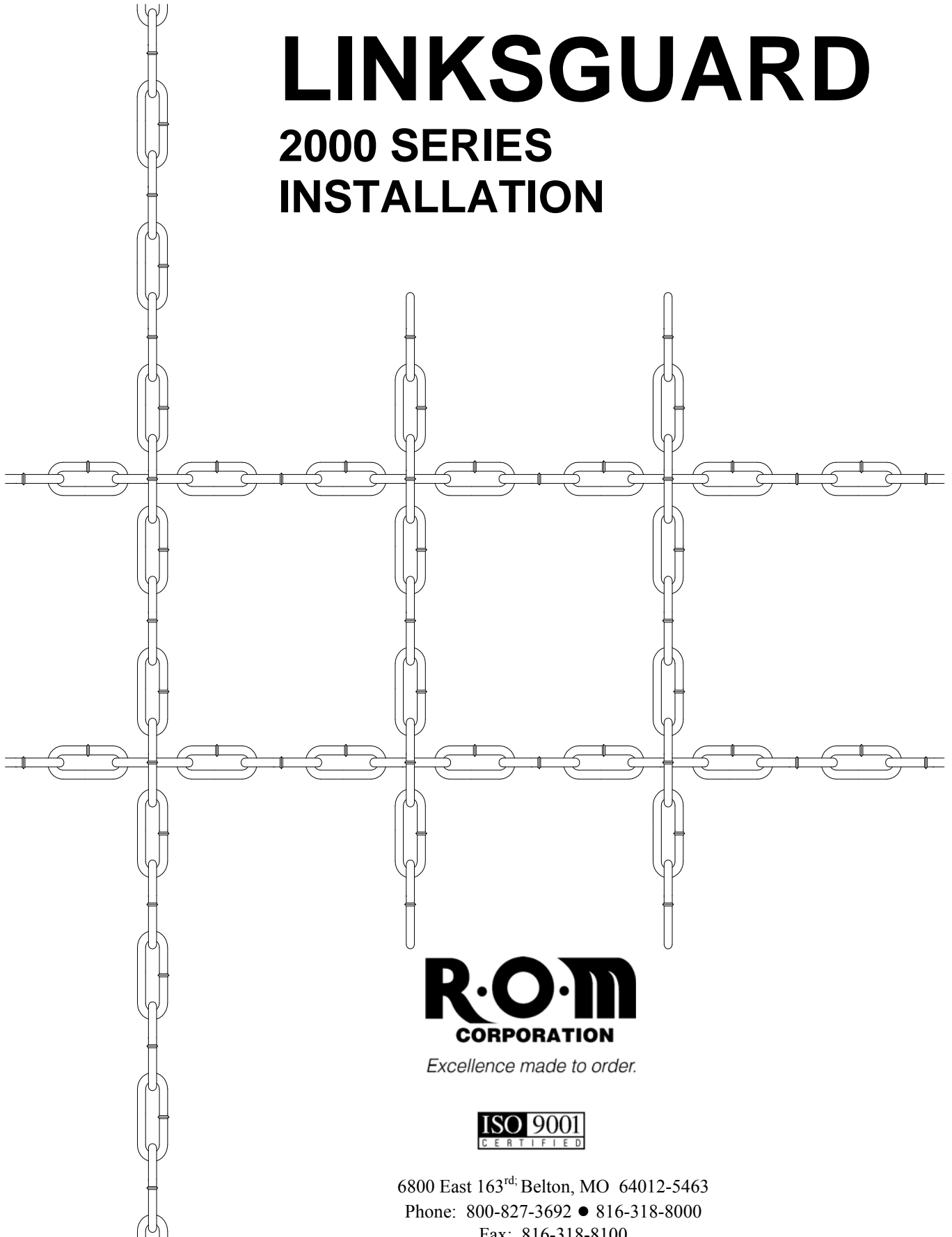

R.O.M.
CORPORATION

Excellence made to order.



6800 East 163rd; Belton, MO 64012-5463

Phone: 800-827-3692 • 816-318-8000

Fax: 816-318-8100

PLEASE NOTE: Measure the opening carefully and compare the dimensions with those on the gate drawing. If there are any discrepancies, please contact your R-O-M representative at 1-800-827-6392 before attempting the installation.

Be certain you are mounting into material capable of supporting the weight of the closure. R-O-M does not supply jamb or lintel support material or any fasteners to mount castings, etc.

Structural Support and Attachment Methods for the Linksguard Closure

**** IMPORTANT ****

The header above the opening must support 1.5 pounds per square foot of gate. For example, a gate is 8'-0" high and 10'-0" wide would weigh a total of 120 pounds. Since it is possible to slide the compressed gate anywhere along the header, fasteners should be selected so the full 120 pounds will be supported anywhere along the length of the track.

The sides of the opening must be of sufficient structural strength to rigidly attach the stationary and closing channels and withstand the impact of the gate during repeated openings. When fastening into wood or masonry, it is recommended the material be at least 1 1/2" thick for fastener gripping. If fastening into any material other than 1 1/2" thick, it is recommended that the fastener be restrained on the backside with a nut or anchor of some type.

All building materials differ in structure and density, for more precise structural recommendations or information contact the architect or builder.

WARNING: When installing a gate with a drop ceiling construct a header, which supports 1.5 pounds per square foot of gate. Do not fasten gate to the drop ceiling.

Fastener Size: The recommended fastener length is 2" long

Gate parts to be attached	Recommended fastener diameter	Number required
Stationary Channel	1/4"	Varies on the length of pre-punched channels
Track, face mounting brackets and radius clips	1/4"	1 per foot of gate width
Male lock block	3/16"	2 ea - flat head fasteners with wall anchors if required

Recommended Fastener Type: Washers are recommended with all fasteners

Material	Fastener type	Material	Fastener type
Wood	Wood screw, lag bolt	Metal-Steel and aluminum	Nut and bolt
Masonry-concrete, brick, etc.	Masonry screw	Metal with unexposed back	Toggle bolt, Moly bolt or Machine screw
Masonry Block	Toggle bolt or Moly bolt	Stone or Marble	Masonry Screw

Interchangeable (IC) Core replacement instructions:

This gate is equipped with Mortise Housings and IC Cores. To remove the IC core on your gate follow these steps:

1. Put the control key (located on the closing channel in a red envelope) and turn the key 15° clockwise.
 2. Adjust the throw pins if needed, then put the core into the cylinder with the control key.
 3. Turn the key 15° counterclockwise and remove the key.
 4. Replace the control key in the envelope on the closing channel.
- Please note: this control key is needed in order to remove the core.

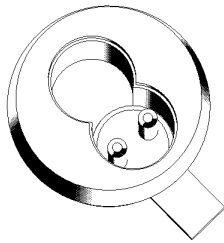

Mortise Housing



IC Core

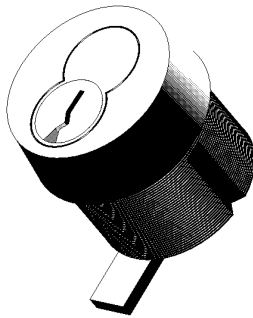

IC Core installed in
Mortise Housing

General Track Mounting Notes:

All closures have two or more sections of track. These sections can be spliced together by positioning two alignment pins between them and following the track mounting steps.

NOTE: DO NOT attach the last section of track until all chain and channels have been hung.

Mounting under lintel track:

1. Align and attach the closing section of track by completing steps 2-4 first. The closing channel will have a factory mounted closing channel stop. (Fig. 2-2) On a bi-parting gate, locate the bi-parting channel shown on the drawing and attach the closing section of track.
2. Raise the track section to the lintel and mark the fastening holes (Fig. 2-3)

3. Lower the track and drill the fastening holes.
4. Attach the track securely to the lintel. If the gate has a radius, this track must be attached as well using radius clips see below for more information.

Mounting radius track:

The radius clips should be equally spaced around the radius of the track alternating from side to side. Shown in Fig. 2-4 is an example of a 9" x 90° radius track. The radius clips should be as close to the upright part of the track as possible. This can be seen in Fig. 2-5.

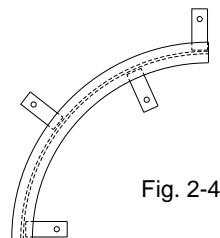
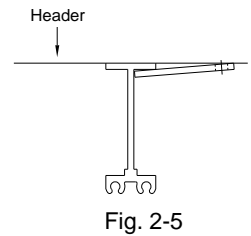
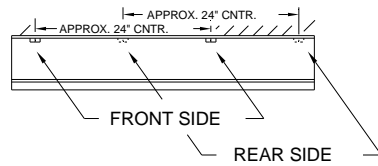
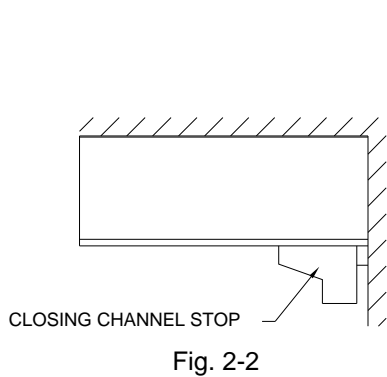

Mounting face mounted track:

1. Align and attach the closing section of track by completing steps 2-5. The closing section will have a factory mounted closing channel stop. (Fig. 2-2) On a bi-parting gate, locate the bi-parting closing channel stop shown on the drawing and attach the closing section of the track.
2. Loosely attach the track to the face mounting brackets, raise the track to the header and mark the fastening holes. (Fig. 3-1)
3. Lower the track and drill fastening holes
4. Remove the brackets from the track and attach them to the header.
5. Mount the track securely to the brackets. If the gate has a radius, this track must be attached as well. The user must supply brackets for a radius in order to meet their particular mounting needs.

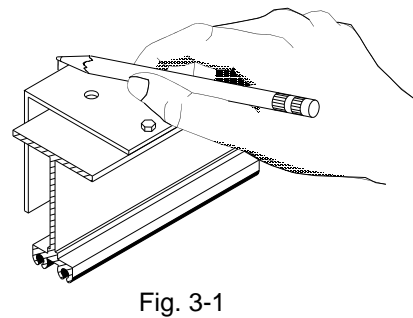
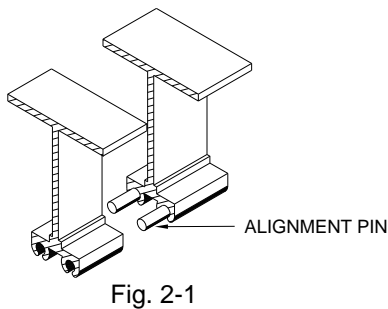

Hanging the chain gate closure:

1. Reference the gate drawing for proper placement of channels and lock positions. Slide the chain carriers with attached chain and the channel assemblies onto the track. Make certain that the closing channel carrier has the lock pin assembly facing the closing channel stop as shown in Fig. 3-2. If any gate height changes are required, make these modifications at the top.

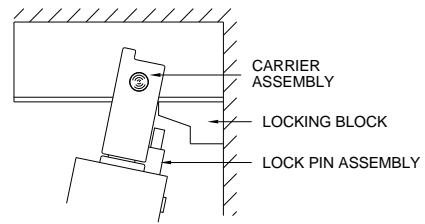

Fig. 3-2

Positioning & Securing the Single Slide Closing Channel

1. Engage the closing channel locking pin into the locking block mounted on the track. (Fig 3-2)
2. Locate and mark the closing channel drop bolt center on the floor. A male lock block (Fig. 4-1) is provided for locking the midsection of the closing channel. Use the male lock block as a spacer between the channel and jamb to insure proper positioning.
3. Drill a $\frac{3}{4}$ " diameter x 1 $\frac{3}{4}$ " deep hole into the floor where it is marked. If floor strike assemblies (Fig. 4-2) are required, the hole should be drilled 1 $\frac{3}{8}$ " x 2 $\frac{5}{16}$ " deep.
4. Calibrate the closing channel drop bolt by following these steps (shown in Fig. 4-3):
 - a. Remove the cam/rod connector from the drop bolt to allow the drop bolt to bottom out on the floor or in the floor strike.
 - b. Turn the "L" handle downward as far as possible.
 - c. Insert the cam/rod connector end back into the optimum hole.
 - d. Turn the "L" handle to retract drop bolt. Slide closure across the opening and check for clearance.
5. Lower the drop bolt into the floor. Place the male lock block into the closing channel.
6. After making certain the lock cam engages into the notch of the block as shown in Fig. 4-4, mark the position of the block on the jamb.
7. Open the channel and mount the male lock block securely to the jamb. If there is not a stud or backing plate, use toggle bolts or wall anchors. Check the operation of the closing channel to be sure it operates smoothly.

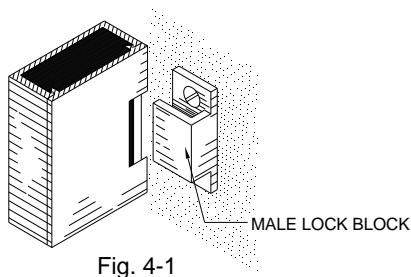

Fig. 4-1

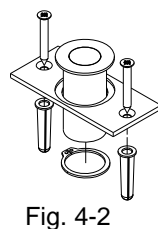

Fig. 4-2

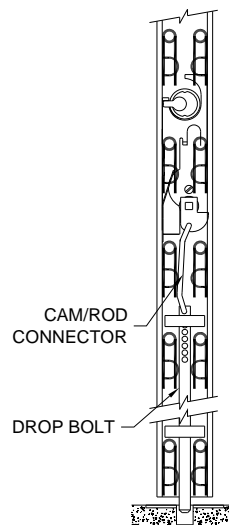

Fig. 4-3

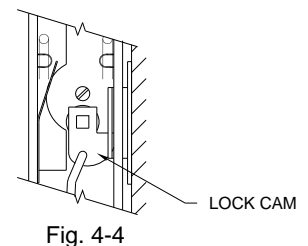

Fig. 4-4

Positioning & Securing the Bi-Parting Closing Channel

1. Engage the bi-part channel locking pins into the closing channel stops. (Fig. 5-1)
2. Engage the mid-section of the closing channel together with the male lock block. (Fig. 5-2)
3. Locate and mark both closing channel drop bolt centers on the floor.
4. Drill a $\frac{3}{4}$ " diameter x 1 $\frac{3}{4}$ " deep hole into the floor where it is marked. If floor strike assemblies (Fig. 5-3) are required, the hole should be drilled 1 $\frac{3}{8}$ " x 2 $\frac{5}{16}$ " deep.
5. Calibrate the closing channel drop bolt by following these steps (shown in Fig. 5-4):
 - e. Remove the cam/rod connector from the drop bolt to allow the drop bolt to bottom out on the floor or in the floor strike.
 - f. Turn the "L" handle downward as far as possible.
 - g. Insert the cam/rod connector end back into the optimum hole.
 - h. Turn the "L" handle to retract drop bolt. Slide closure across the opening and check for clearance.
6. Check the operation of the closing channel to be sure it operates smoothly.

Attaching the chain:

1. Insert the leading horizontal link into its corresponding slot in the channel. Then place the chain retaining spring into the chain link as shown in Fig. 5-5. Repeat this procedure on all horizontal chains.

PLEASE NOTE: The spring coil on the chain retainer can be installed in either direction to fit around objects in the channel. Place the springs in the lock area so that they DO NOT interfere with the operation of the lock pawl or the slide plate. (Fig. 3-4 on page 3)

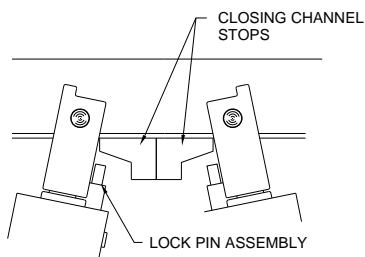

Fig. 5-1

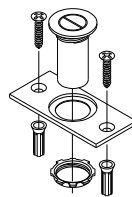

Fig. 5-3

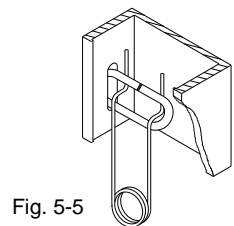

Fig. 5-5

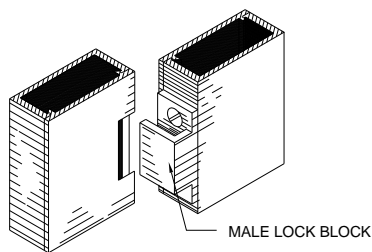

Fig. 5-2

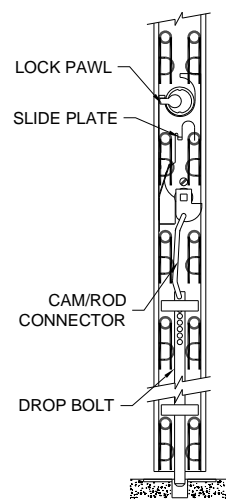

Fig. 5-4

L-Clip Installation

1. Insert the end of the chain into the last slot located $\frac{1}{2}$ " from the bottom of the channel. (Fig. 6-1)
2. Place the L-Clip over the chain, inside the channel. Making sure the longer leg is flush against the inside edge of the channel and the short leg is towards the bottom of the channel.

Note: Only one L-Clip is required per channel. If the channel is an intermediate channel (one with slots on both sides), use whichever side you would like.

3. Install the chain retaining spring with the end of the chain against the L-Clip.

Positioning and securing the stacking channel:

- **A stationary channel:** Mount this channel directly under the track and into the jamb. The channel should be the same distance from the floor as the other channels
- **A stopping channel:** Lock the closing channel and pull the stopping channel toward the stacking end until horizontal chain is taut. Hold the channel in place with vice grips. Mark and drill track for stop blocks placement as shown in Fig. 6-2, mount the stop blocks, then mark and drill the drop bolt hole location.
- **A pocket/plater channel:** Slide this channel into the pocket. Attach the four angle brackets that are provided at alternating heights on both sides of the pocket, equal distance apart and flush with the front edge of the pocket. (Fig. 6-3)

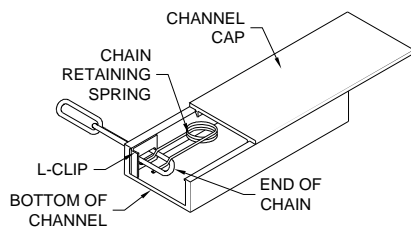

Fig. 6-1

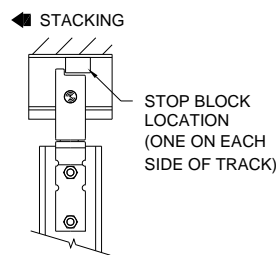

Fig. 6-2

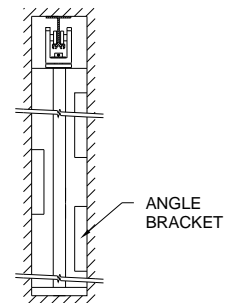

Fig. 6-3

Completing the installation

1. Visually inspect the gate. The chain mesh should not have any slack. If slack is present and cannot be taken out by moving the stopping channel, cut off the necessary links nearest the stationary or stopping channel and reattach the chain.
2. Mark and drill the drop bolt hole locations for the intermediate channels.
3. Calibrate all locking channels remaining by referencing page 6; instruction 4 for detailed instructions.
4. Before installing the cap; make sure the L-Clip in Fig. 6-1 is installed. This will keep the cap from dragging the ground if the cap slides easily in the channel.
5. Locking the channel with the key prior to installing the cap will prevent the slide plate from sliding off the mortise lock and falling out of the channel while installing the cap.

6. Snap the caps on all channels using a rubber mallet (Fig. 5-2). The closing channel cap has a notch. This notch must be facing the male lock block for proper operation.
7. Review the Linksguard Users Guide with each person who will be operating the closure. Leaving that information and closure keys with the owner.

This completes the installation of your Linksguard 2000 series closure. If you have any questions contact your R-O-M representative at 1-800-827-3692.

Copyright © 2010 ROM Corporation. All Rights Reserved. These drawings and the information contained herein are the confidential and proprietary intellectual property of ROM Corporation and should not be disclosed to any third party without the express prior written consent of ROM Corporation