



Excellence made to order.

6800 East 163rd Street
Belton, MO 64012-5463
816 318-8000
1-800-827-3692
FAX 816-318-8100



DUROMATIC INSTALLATION INSTRUCTIONS

FM-7.5-80
Revision A
3/28/2008

Congratulations on your purchase of the ROM DuroMatic Self-Closing Strip Door.

You will need the following parts and tools to install your DuroMatic:

- See parts list and illustration diagram for parts provided on pages 5
- Tape Measure (not included)
- Pencil or Marker (not included)
- Drill (not included)
- Drill Bits – 3/16" (not included)
- Power Bit Adapter (not included)
- 3/8" Socket (not included)
- 7/16" Socket (not included)
- (12) ¼-14 x 2" or 2 ½ Self-Drilling Hex Washer Head Screws—depending on trailer wall/ceiling thickness (not included)

Notice: Do not force the closer arm closed. Doing so will damage the closure and void your warranty. The factory setting is for an approximate 30 second delay.

Getting started:

Prior to starting, check the parts list on page 5 to make sure you received all the parts you will need to complete the installation. If you are missing any parts, call 800-827-3692 to get those parts sent to you.

Closer Mount Assembly Plate:

1. Measure and mark the center of the door. This mark needs to go up to the ceiling. Line up the right side of the closer mount assembly plate with the center mark and flush with the ceiling. *Please note: Curbside installation is shown throughout these instructions.*
2. Mark two mounting holes on the plate and two mounting holes on top flange as shown in Fig. 1. Pre-drilling these holes will make for easier installation. The screws should be long enough to go through the top header plate or something that will support the load of the assembly.
3. Install the closer mount plate using the recommended hardware listed above.

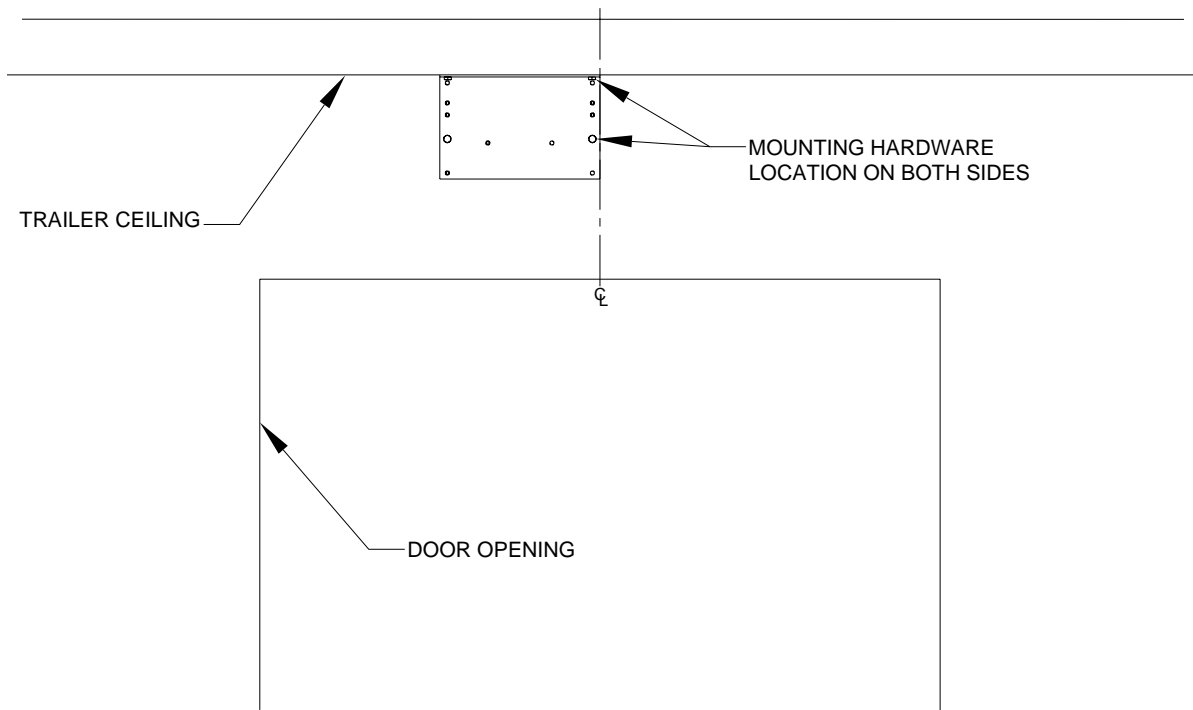

FIG. 1

Installing the closer:

1. If your door is on the curbside the closer arm will be towards the front of the trailer.
2. Place the closer on the threaded studs and secure with four ¼-20 nylon insert nuts.

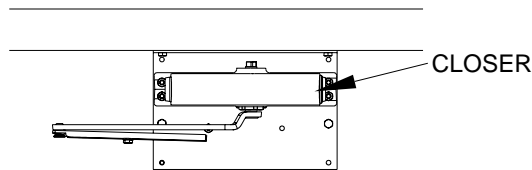

FIG. 2

Installing the track:

1. Place the track splice plate on the threaded stud located on the closer mount plate as shown in Fig. 3 and secure with a ¼-20 nylon insert nut. The closer arm will need to be held in the open position in order to install this nut.
2. Making sure the track splice wall top angle is flush with the top of the ceiling, match drill using the top or bottom hole in the track splice wall part and secure using the recommended self drilling fastener. The top hole should be used for secure mounting.
3. Place the 32" trolley in the end of the track; it should move freely.

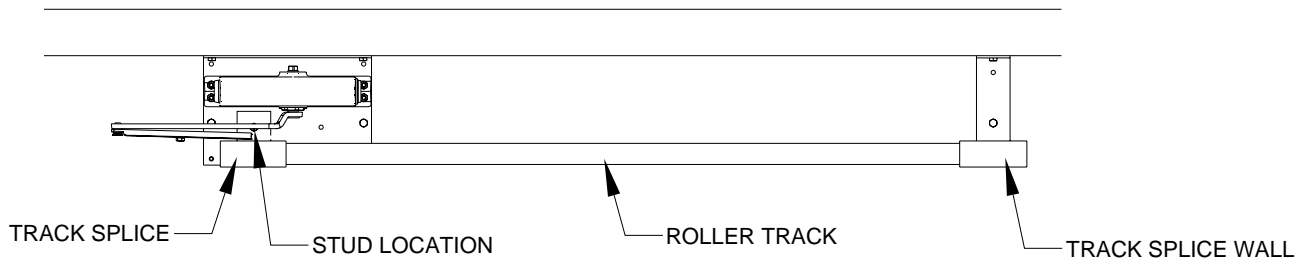

FIG. 3

Installing the guard assembly:

1. Install the 15" wall mount bracket on the threaded stud located at the end of the guard assembly.
2. Lift the guard assembly above the door and place the other end of the 15" wall mount bracket on the threaded stud located on the closer mount plate. This will be the mounting location for the guard.
3. Mark the mounting holes locations for one bolt on the guard plate and one thru the top flange. Remove guard assembly and pre-drill.
4. Re-install the guard assembly by first positioning the 15" wall mount bracket and tightening the 1/4-20 insert nut then the guard mounting screws.
5. Locate the shoe connector and attach to the closer arm using the hardware provided on the closer. Then, install into the arm on the closer unit.
6. Install the eyebolt and nut on the closer arm.

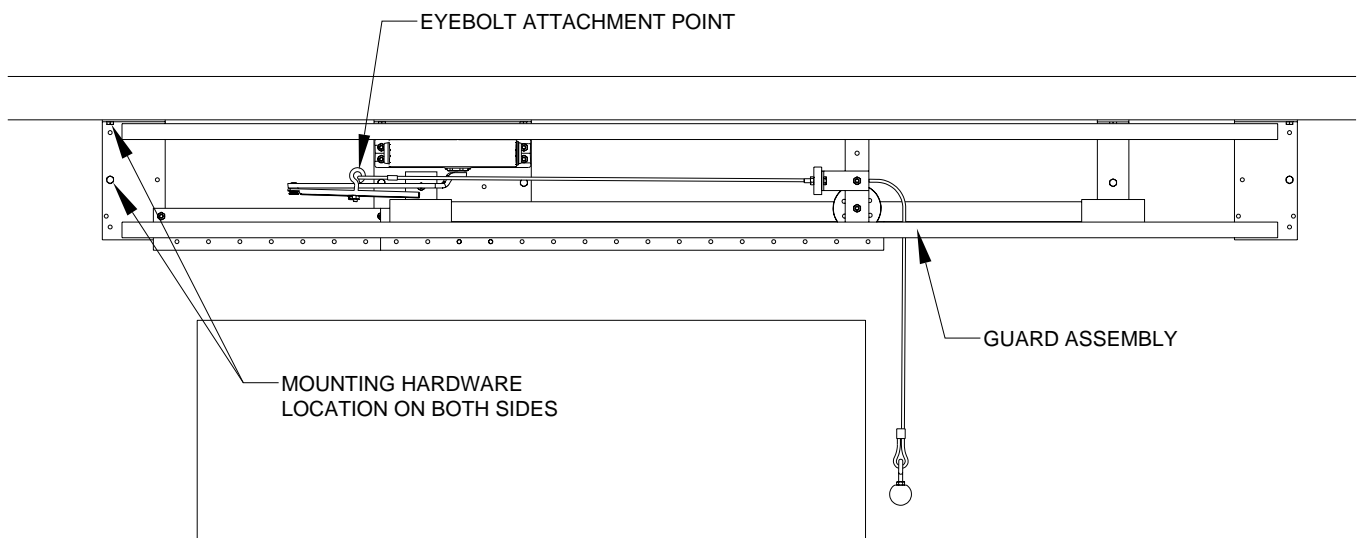

FIG. 4

Installing the curtains:

Please note: The curtains have a slight radius contour to their profile; Fig. 5a shows how to overlap the radii on the curtains to minimize escaping air when the DuroMatic unit is closed.

To install the curtain strips you will need the ¼-20 K-lock nuts and clamp plates. To provide the maximum benefit the curtains will need to be installed the following way: On the moveable trolley, install one curtain strip so the end hole matches up with the last hole on the trolley. Then, skip two threaded studs; install the next curtain then repeat for the next strip. On the 15" wall mount bracket, install the curtain strip so the end hole matches up with the last threaded stud on the mount bracket. Reference Fig. 5 for an example of how the curtain strips should look at this point. When this is complete, install the other curtain strips so that they overlap. After installing the clamp plates, install the shoe connector over the clamp plate and threaded stud that lines up when the closer is in the closed position. Once all clamp plates are in place the ¼-20 K-lock nuts can be installed.

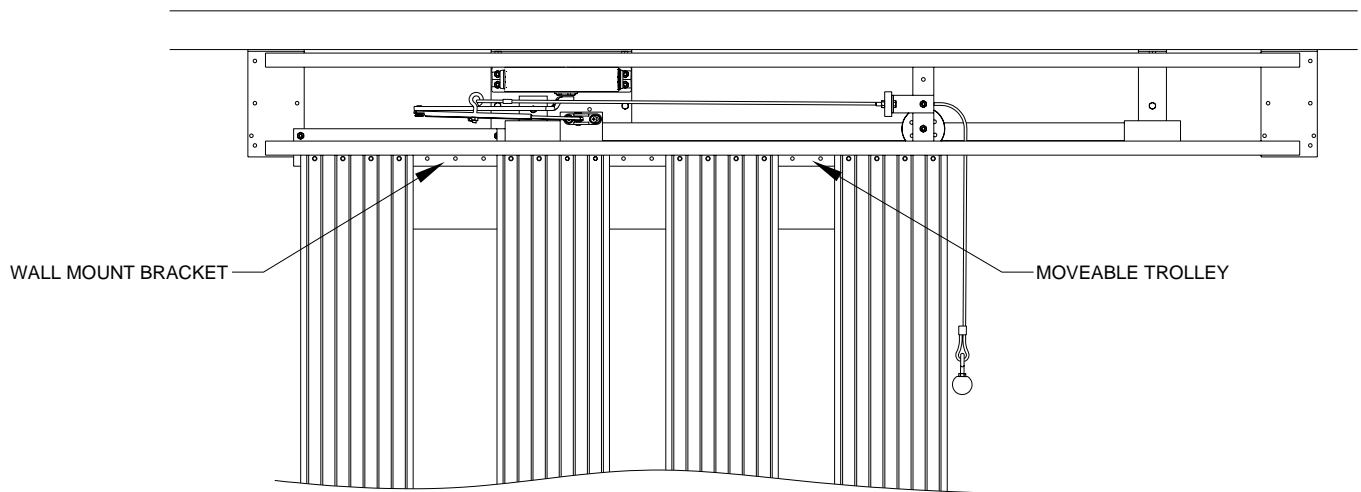

FIG. 5

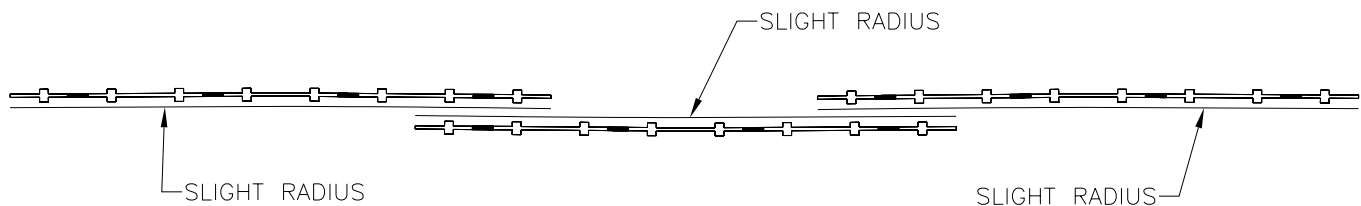
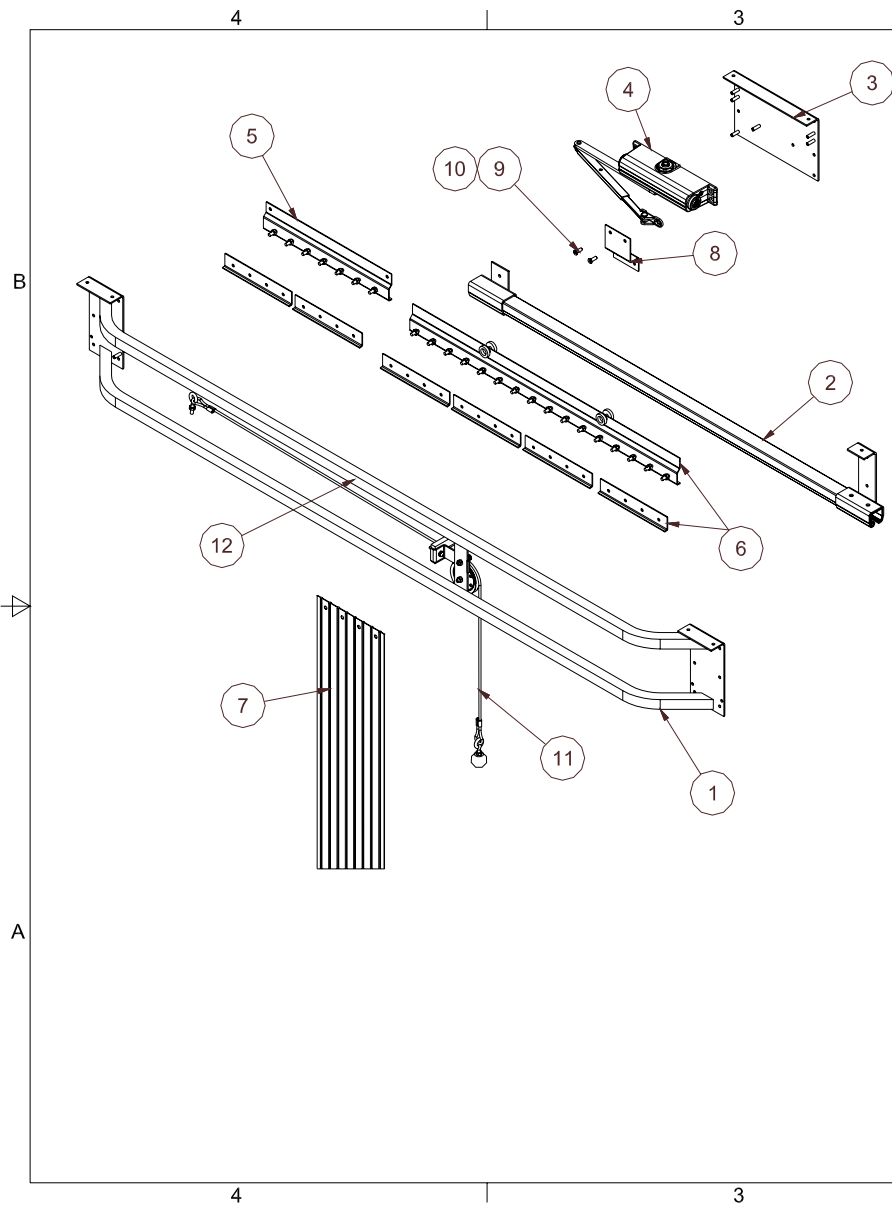

FIG. 5a

This completes the installation of the DuroMatic Self-Closing Strip Door. To operate the unit, pull the cable assembly knob until the closer engages. The curtain will open for approximately 30 seconds then close. If you have any questions contact your R-O-M representative at 1-800-827-3692.

Copyright © 2008 ROM Corporation. All Rights Reserved. These drawings and the information contained herein are the confidential and proprietary intellectual property of ROM Corporation and should not be disclosed to any third party without the express prior written consent of ROM Corporation

EXPLODED DRAWING WITH PARTS LISTS



REVISION HISTORY				
LTR	ECN NO	DESCRIPTION	DATE	BY
A	724	PART CREATION	04/03/08	BAM
B	728	UPDATED BOM	04/14/08	BAM
C	731	UPDATED BOM	04/29/08	BAM

NO.	DESCRIPTION	SELLABLE	ITEM	QTY.
13	SERIAL PLATE LOADMAKER	YES	R00499	1
12	LABEL DUROMATIC	YES	R02393	1
11	CABLE ASSY DUROMATIC	YES	R02396	1
10	1/4-20 NYL INS STOP NUT ZP	YES	10021	9
9	1/4-20 X 3/4 FH MACH SCR ZP	YES	R02408	2
8	SHOE CONNECTOR DUROMATIC	YES	R02383	1
7	CURTAIN CUT DUROMATIC	YES	R02392	7
6	TROLLEY 32 IN W/ CLAMP PLATES DUROMATIC	YES	R02409	1
5	WALL MOUNT 15 IN DUROMATIC	YES	R02381	1
4	CLOSER DRILLED DUROMATIC	YES	R02375	1
3	CLOSER MOUNT ASSY DUROMATIC	YES	R02398	1
2	TRACK SUB ASSY DUROMATIC	YES	R02413	1
1	GUARD ASSY DUROMATIC	YES	R02397	1

Parts List					
 <p>6800 E. 163rd Street Belton, MO 64012-5463 (816) 318-8000 (800) 827-3692 Fax (816) 318-8100 www.romcorp.com</p> <p>Excellence made to order.</p>		DUROMATIC CURTAIN			
		DUROMATIC CURTAIN			
Copyright © 2008 R-O-M Corporation. All Rights Reserved. This drawing and the information contained herein are the confidential and proprietary Intellectual property of R-O-M Corporation and should not be disclosed to any third party without the prior written consent of R-O-M Corporation. Dimensions are in Inches unless otherwise noted.	Size B C	Scale NTS R02369	Date 2/28/2008 Sheet 2	Drawn BAM Drawing No. R02369	Checked